

This catalog covers:
FH541V-□G80

This fig. covers:
TITLE

PARTS CATALOG

4-STROKE ENGINE

FH541V

PRODUCT CODE	NOTE
FH541V-AG80	MOWER

PARTS CATALOG INTRODUCTION

This parts catalog lists parts and sub-assemblies provided as service parts.

When it becomes necessary to replace parts, always use KAWASAKI GENUINE PARTS which have passed strict inspection which guarantees quality and performance.

1. HOW TO ORDER PARTS

- When ordering the parts, be sure to use the parts catalog corresponding to the product code. Check the product revision codes on the product and the catalog.
 Product Code (example) : FA130D-AA00
└──────────────────┘
 Product Revision Code
- Specify the part code (all digits) exactly as listed in this catalog on your parts order.
- The parts not shown in the illustrations of this catalog are not sold separately; only the complete units or next higher assemblies illustrated are supplied as the service parts.

2. EXPLANATION OF PARTS CATALOG FORMAT

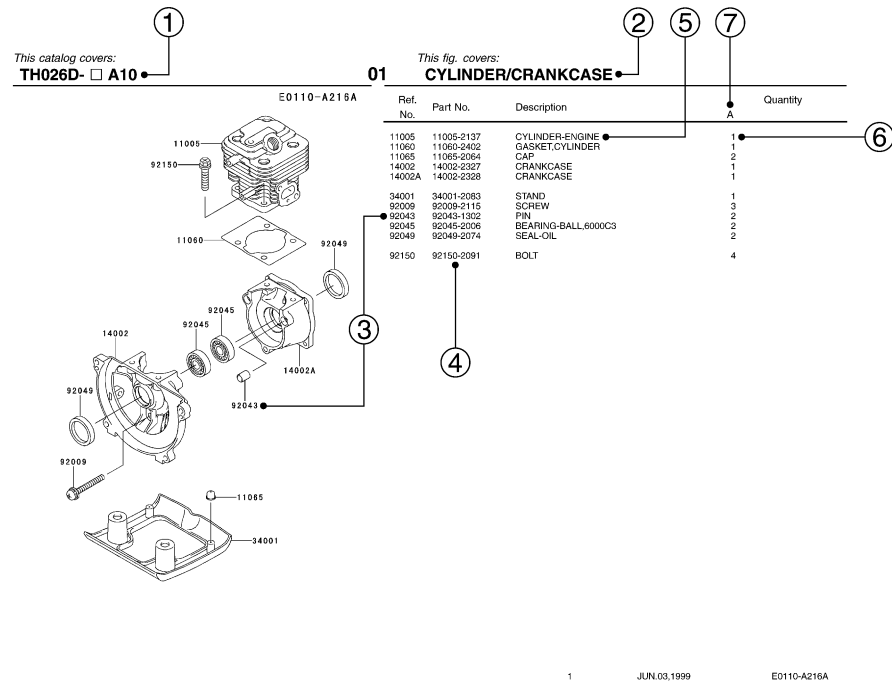

1) Product Code

This code describes the product code covered by this catalog. The product revision code, which is a part of the product code, is omitted.

2) Part Group Title

This title is the representative name for the group of parts illustrated on the page.

3) Reference Number

The reference numbers are shown on the illustration and the list as the link between them.

4) Part Number

This is the key of your parts ordering.

Three kinds of part number are used in this catalog.

a. Structure 1

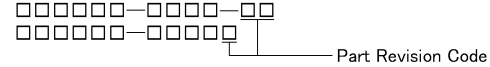

b. Structure 2

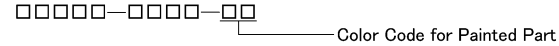

c. Standard Hardware Number

(for bolts, nuts, washer, or the like)

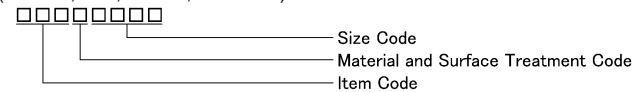

5) Description and Additional Information

The part name, the location, the size, and the serial number as additional information, etc. are described here. Use them to find out and check the part required.

When a part number is changed without change of the product revision code and the changed parts are not interchangeable, the serial number of the product is noted as follows;

- (FA130 - 100001) : Affected units are from beginning of the product of the product code up to and including this serial number.
- (FA130 - 100002 -) : Affected units are from this serial number and above.
- (FA130 - 100002 - FA130 - 110001) : Affected units are in this serial number range.

6) Quantity

The figure shows quantity of the part required at the indicated position on the illustration and for the specified product revision code.

The asterisk (*) on this column means the part can be used as the substitute on the product and is supplied until the stock is exhausted.

Note:Some small parts will be supplied by units.

Example: If six (6) bolts are ordered and the minimum quantity per unit is five (5), two (2), units of the bolt will be delivered.

7) Product Revision Code

This Code indicates an important change which affects the service parts interchangeability.

3. ABBREVIATIONS

#.....Number	FR.....Front	RH.....Right Hand
&.....And	G.....Gram	RPM.....Revolutions Per Minute
(+).....Plus	HEX.....Hexagonal	RR.....Rear
(-).....Minus	ID=.....Inside Diameter	STD.....Standard
2ND.....Second	IN.....Inch	T.....Teeth
3RD.....Third	L=.....Length	T=.....Thickness
4TH.....Fourth	LH.....Left Hand	U/S.....Under Size
A.....Ampere	LWR.....Lower	UPP.....Upper
AR.....As Required	MM.....Millimeter	V.....Volt
ASSY.....Assembly	O/S.....Over Size	W.....Watt
CNT.....Center	OD=.....Outside Diameter	
COMP.....Complete	REF.....Reference	

This catalog covers:

FH541V- □ G80

This fig. covers:

01 CYLINDER/CRANKCASE

E0110-A408U

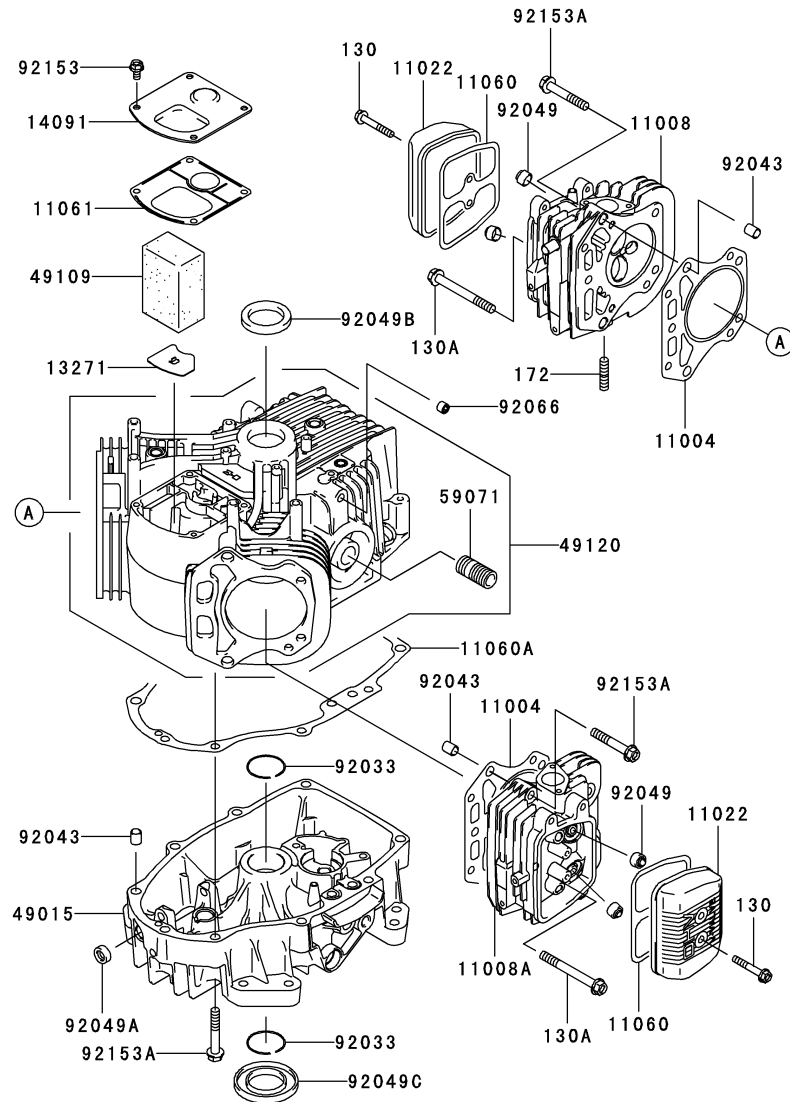

Ref. No.	Part No.	Description	Quantity
11004	11004-7016	GASKET-HEAD	2
11008	11008-6043	HEAD-COMP-CYLINDER,#1	1
11008A	11008-7020	HEAD-COMP-CYLINDER,#2	1
11022	11022-7018	CASE-ROCKER	2
11060	11060-7001	GASKET,ROCKER CASE	2
11060A	11060-7008	GASKET,CRANKCASE COVER	1
11061	11061-7001	GASKET,BREATHER	1
13271	13271-7016	PLATE	1
14091	14091-7006	COVER	1
49015	49015-6253	COVER-CRANKCASE	1
49109	49109-7002	ELEMENT-BREATHER	1
49120	49120-7113	CRANKCASE-COMP	1
59071	59071-2079	JOINT	1
92033	92033-7003	RING-SNAP	2
92043	92043-7001	PIN	6
92049	92049-7001	SEAL-OIL,RVC2 6X11X10.2	4
92049A	92049-7005	SEAL-OIL,SO 8X14X5 HS	1
92049B	92049-7010	SEAL-OIL,SD 35X48X8 R HS	1
92049C	92049-7011	SEAL-OIL,SD 35X62X8 L HS	1
92066	92066-7002	PLUG	1
92153	92153-7043	BOLT,6X12	4
92153A	92153-7054	BOLT,8X50	17
130	130AA0640	BOLT-FLANGED,6X40	4
130A	130CA0875	BOLT-FLANGED,8X75	2
172	172BA0818	BOLT-STUD,8X18	4

This catalog covers:

FH541V- □ G80

02

This fig. covers:

PISTON/CRANKSHAFT

E0120-A386A

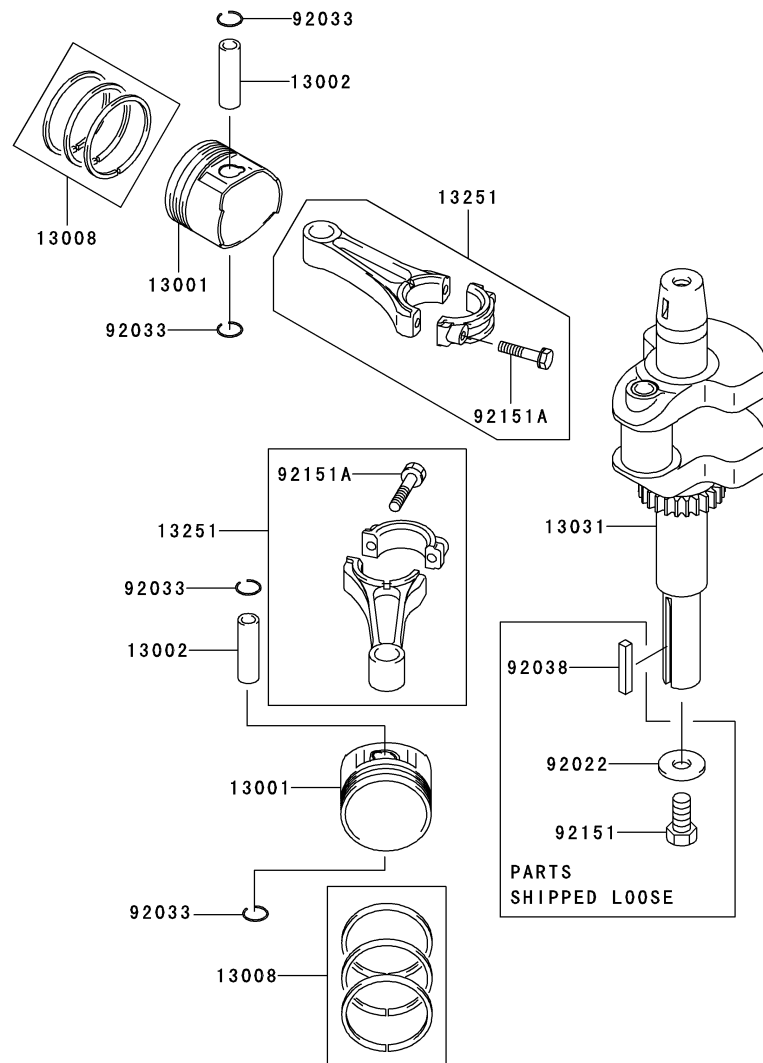

Ref. No.	Part No.	Description	Quantity
13001	13001-7010	PISTON-ENGINE	2
13002	13002-7001	PIN-PISTON	2
13008	13008-6060	RING-SET-PISTON	2
13031	13031-7073	CRANKSHAFT-COMP	1
13251	13251-7010	ROD-ASSY-CONNECTING	2
92022	92022-1982	WASHER, 12.5X32X3.2	1
92033	92033-7002	RING-SNAP	4
92038	92038-2101	KEY	1
92151	92151-7010	BOLT, 7/16-20UNF	1
92151A	92151-7017	BOLT, 6X35	4

This catalog covers:

FH541V- □ G80

03

This fig. covers:

VALVE/CAMSHAFT

E0130-A119A

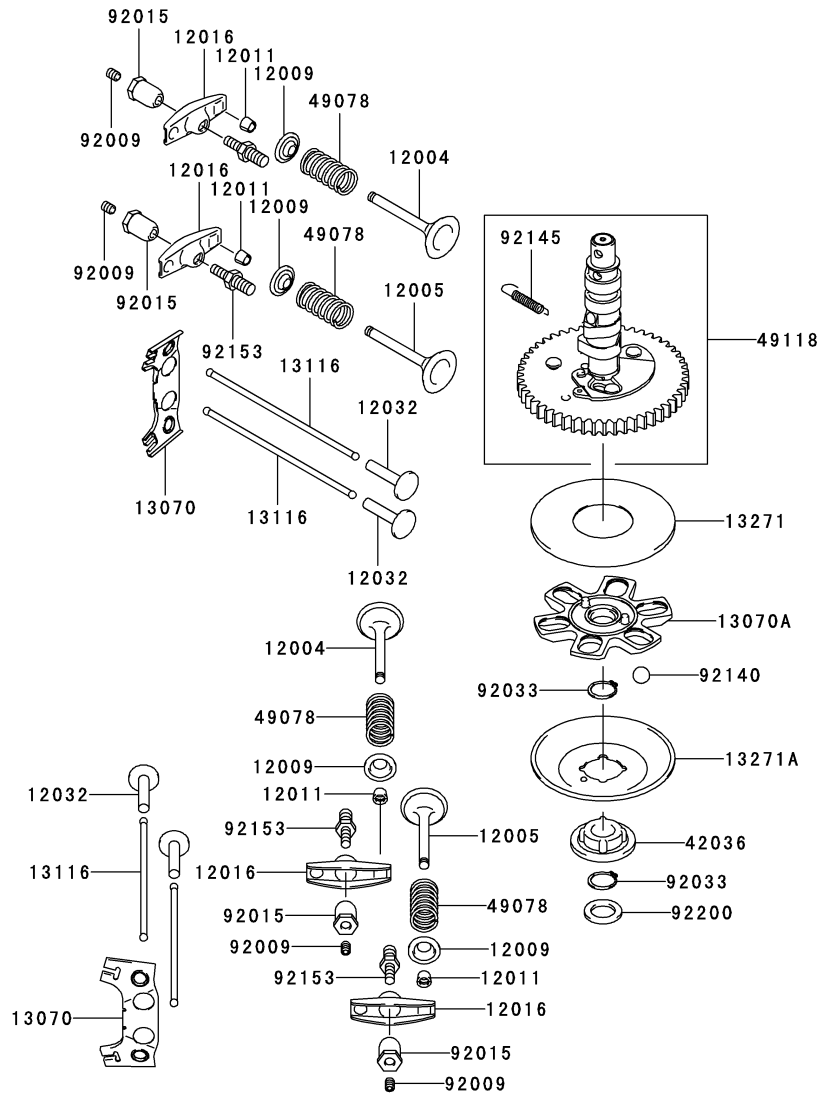

Ref. No.	Part No.	Description	Quantity
12004	12004-7003	VALVE-INTAKE	2
12005	12005-7003	VALVE-EXHAUST	2
12009	12009-7001	RETAINER-VALVE SPRING	4
12011	12011-2056	COLLET	8
12016	12016-7008	ARM-ROCKER	4
12032	12032-7001	TAPPET	4
13070	13070-7001	GUIDE	2
13070A	13070-7004	GUIDE	1
13116	13116-2057	ROD-PUSH	4
13271	13271-7007	PLATE	1
13271A	13271-7021	PLATE,GOVERNOR	1
42036	42036-7010	SLEEVE	1
49078	49078-7001	SPRING-ENGINE VALVE	4
49118	49118-7004	CAMSHAFT-COMP	1
92009	92009-2341	SCREW	4
92015	92015-2253	NUT	4
92033	92033-7001	RING-SNAP	2
92140	92140-7005	BALL	6
92145	92145-7001	SPRING	1
92153	92153-7019	BOLT	4
92200	92200-7001	WASHER	1

This catalog covers:

FH541V- □ G80

This fig. covers:

04 LUBRICATION-EQUIPMENT

E0140-A202D

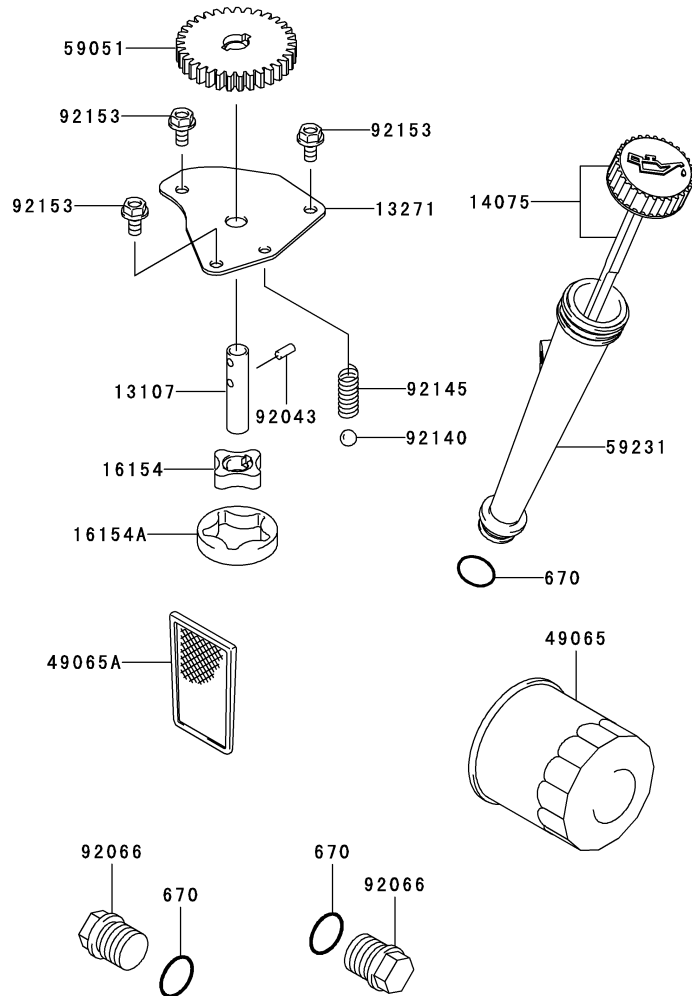

Ref. No.	Part No.	Description	Quantity
13107	13107-7009	SHAFT	1
13271	13271-7017	PLATE	1
14075	14075-7009	CAP-ASSY	1
16154	16154-2053	ROTOR-PUMP,IN	1
16154A	16154-2054	ROTOR-PUMP,OUT	1
49065	49065-2078	FILTER-OIL	1
49065A	49065-7004	FILTER-OIL	1
59051	59051-7011	GEAR-SPUR	1
59231	59231-7005	FILLER	1
92043	92043-7003	PIN	2
92066	92066-7003	PLUG	2
92140	92140-7003	BALL	1
92145	92145-7002	SPRING	1
92153	92153-7043	BOLT,6X12	3
670	670D2016	O RING,16MM	3

This catalog covers:

FH541V- □ G80

This fig. covers:

05 COOLING-EQUIPMENT

E0150-A759B

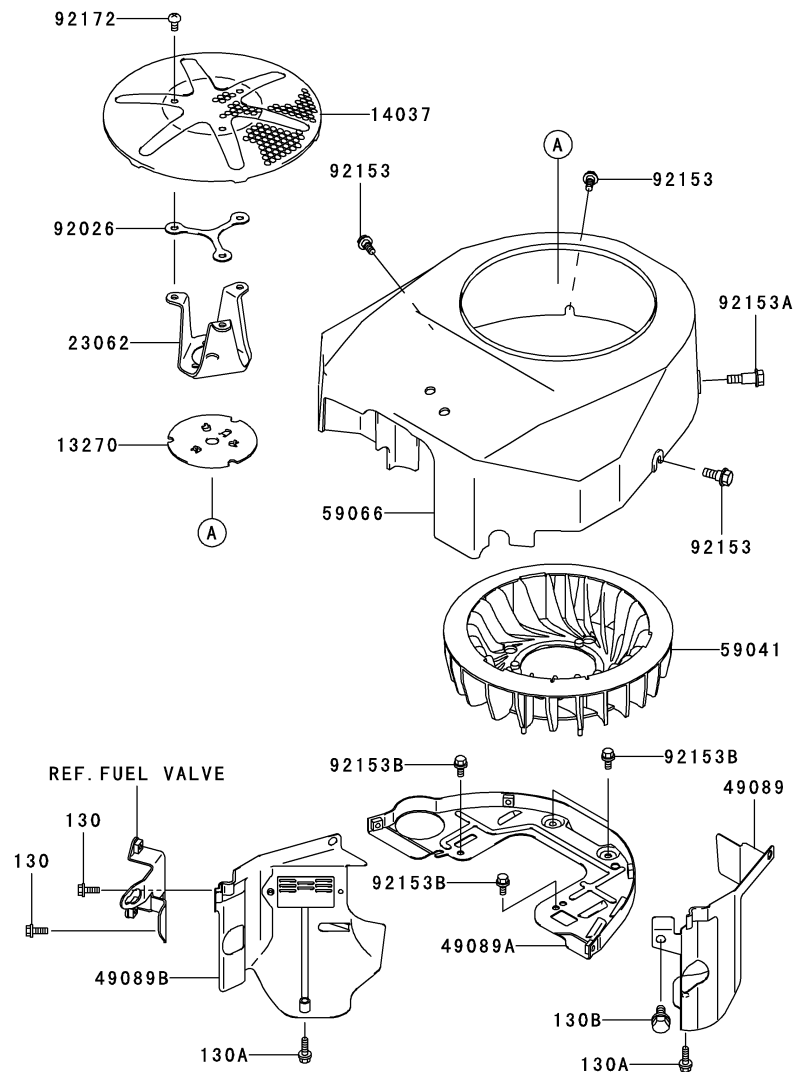

Ref. No.	Part No.	Description	Quantity
13270	13270-7007	PLATE	1
14037	14037-7020-9H	SCREEN	1
23062	23062-7010	BRACKET-COMP	1
49089	49089-7002	SHROUD-ENGINE	1
49089A	49089-7032	SHROUD-ENGINE	1
49089B	49089-7034	SHROUD-ENGINE	1
59041	59041-7012	FAN	1
59066	59066-7011	HOUSING-FAN	1
92026	92026-7007	SPACER	AR
92153	92153-7007	BOLT	3
92153A	92153-7008	BOLT	1
92153B	92153-7043	BOLT,6X12	4
92172	92172-7029	SCREW,SOCKET,6X12	3
130	130AA0616	BOLT-FLANGED,6X16	2
130A	130AA0625	BOLT-FLANGED,6X25	2
130B	130AA0816	BOLT-FLANGED,8X16	1

This catalog covers:

FH541V- □ G80

06

This fig. covers:

ELECTRIC-EQUIPMENT

E0160-B248A

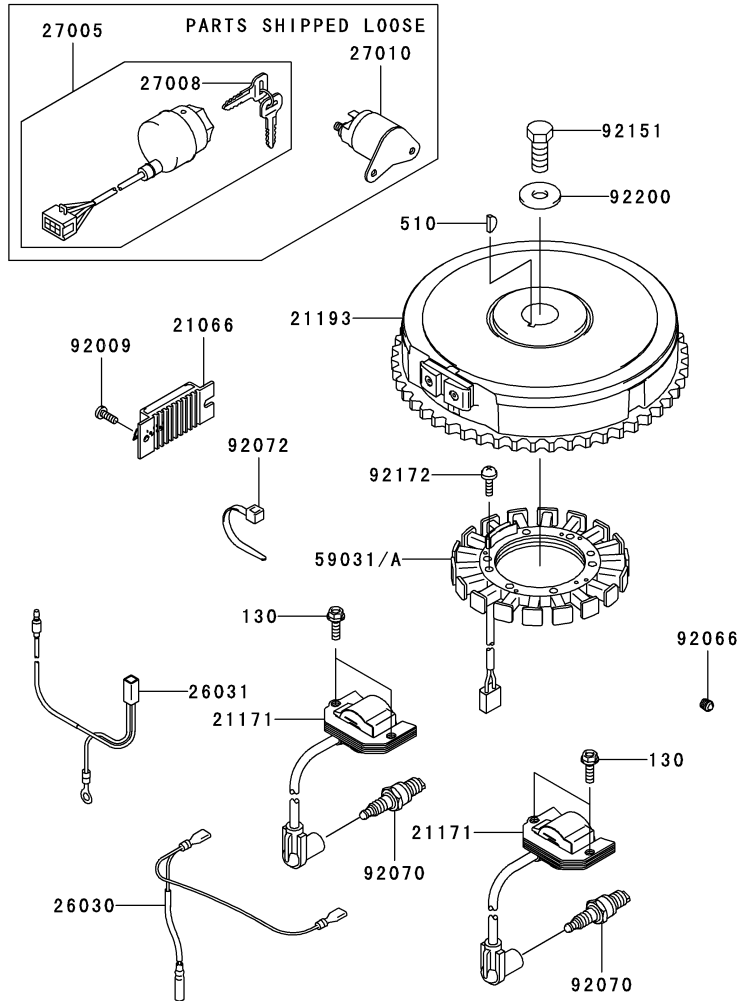

Ref. No.	Part No.	Description	Quantity
21066	21066-7011	REGULATOR-VOLTAGE	1
21171	21171-7034	COIL-ASSY-IGNITION	2
21193	21193-7032	FLYWHEEL-ASSY	1
26030	26030-7001	HARNESS	1
26031	26031-7012	HARNESS	1
27005	27005-2056	SWITCH-ASSY-IGNITION	1
27008	27008-2055	KEY-LOCK	2
27010	27010-2154	SWITCH	1
59031	59031-7009	COIL-CHARGING	*
59031A	59031-7014	COIL-CHARGING	1
92009	92009-2308	SCREW	1
92066	92066-7002	PLUG	1
92070	92070-7003	PLUG-SPARK,RCJ8Y,SOLID	2
92072	92072-7003	BAND	3
92151	92151-2097	BOLT,12X30	1
92172	92172-7018	SCREW,5X20	4
92200	92200-7002	WASHER	1
130	130AA0620	BOLT-FLANGED,6X20	4
510	510A5100	KEY-WOODRUFF	1

This catalog covers:

FH541V- □ G80

07

This fig. covers:

CONTROL-EQUIPMENT

E0170-A445L

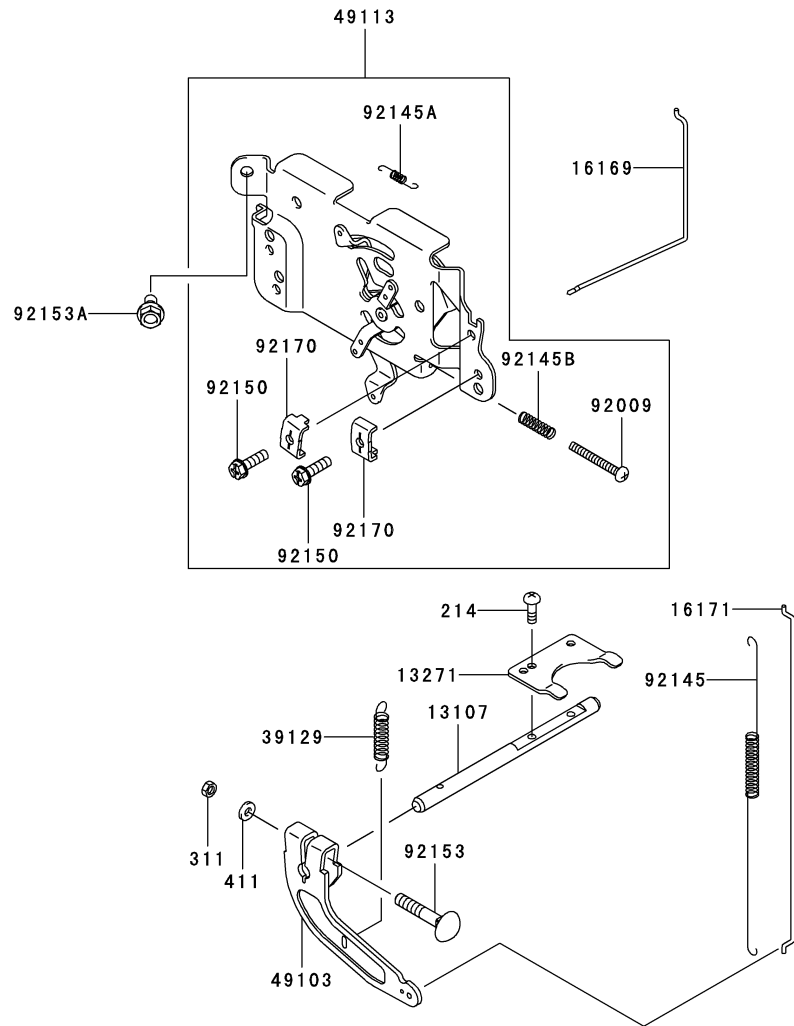

Ref. No.	Part No.	Description	Quantity
13107	13107-7010	SHAFT	1
13271	13271-7032	PLATE	1
16169	16169-7010	LINK-CHOKE	1
16171	16171-7001	LINK	1
39129	39129-7003	SPRING-GOVERNOR	1
49103	49103-7004	ARM-GOVERNOR	1
49113	49113-7011	PANEL-COMP-CONTROL	1
92009	92009-7007	SCREW,4X35	1
92145	92145-7003	SPRING	1
92145A	92145-7004	SPRING	1
92145B	92145-7005	SPRING	1
92150	92150-2182	BOLT,5X18	2
92153	92153-7033	BOLT,6X35	1
92153A	92153-7043	BOLT,6X12	2
92170	92170-7001	CLAMP	2
214	214AA0408	SCREW-PAN+,-,4X8	2
311	311AA0600	NUT-HEX,6MM	1
411	411AA0600	WASHER-PLAIN,6MM	1

This catalog covers:

FH541V- □ G80

This fig. covers:

08 CARBURETOR

E0180-A760A

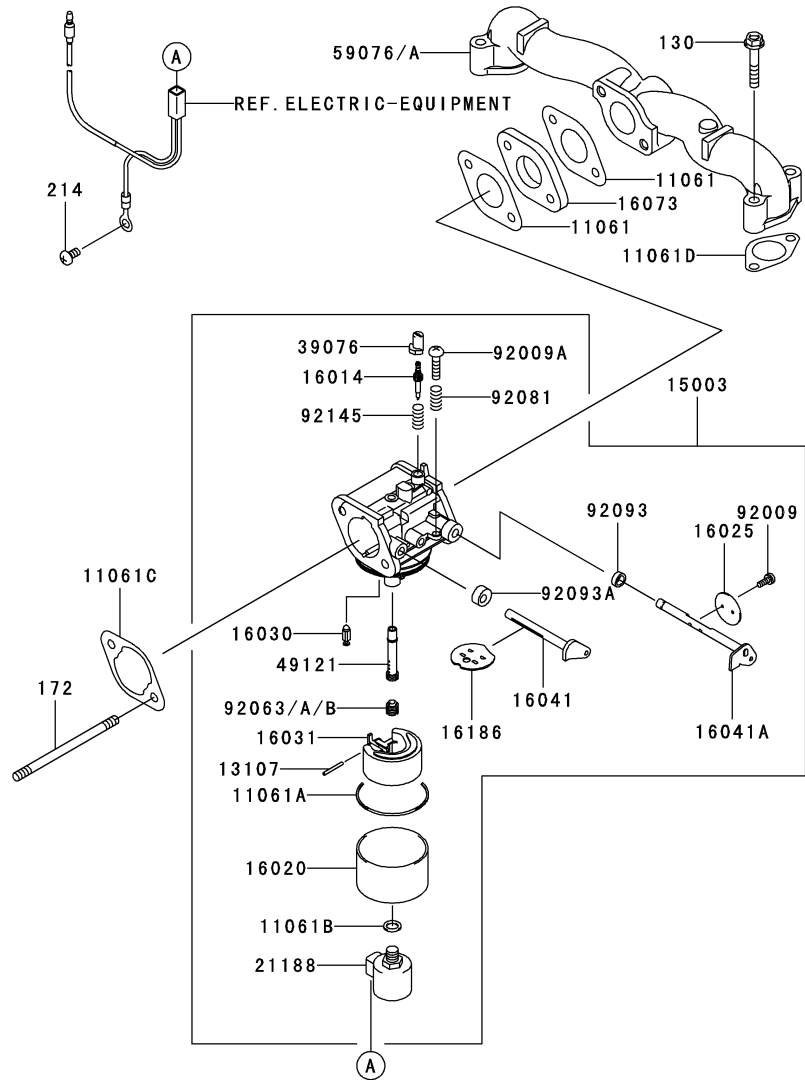

Ref. No.	Part No.	Description	Quantity
11061	11061-7004	GASKET,INSULATOR	2
11061A	11061-7009	GASKET,CHAMBER	1
11061B	11061-7010	GASKET,SCREW	1
11061C	11061-7018	GASKET,AIR CLEANER	1
11061D	11061-7019	GASKET	2
13107	13107-7018	SHAFT	1
15003	15003-7086	CARBURETOR-ASSY	1
16014	16014-7007	SCREW-PILOT AIR	1
16020	16020-7003	CHAMBER-FLOAT	1
16025	16025-7006	VALVE-THROTTLE	1
16030	16030-7003	VALVE-FLOAT	1
16031	16031-7002	FLOAT	1
16041	16041-7016	SHAFT-CARBURETOR,CHOKE	1
16041A	16041-7018	SHAFT-CARBURETOR,THROTTLE	1
16073	16073-7007	INSULATOR	1
16186	16186-7004	VALVE-ASSY-CHOKE	1
21188	21188-7002	SOLENOID	1
39076	39076-7001	LIMITER	1
49121	49121-7007	NOZZLE-MAIN	1
59076	59076-7001	MANIFOLD-INTAKE	*
59076A	59076-7017	MANIFOLD-INTAKE	1
92009	92009-2083	SCREW	2
92009A	92009-2349	SCREW	1
92063	92063-7046	JET-MAIN,#100	1
92063A	92063-7047	JET-MAIN,#098,3280FT	AR
92063B	92063-7063	JET-MAIN,#96,6560FT	AR
92081	92081-2234	SPRING	1
92093	92093-2100	SEAL	1
92093A	92093-7003	SEAL	1
92145	92145-7015	SPRING	1
130	130AA0635	BOLT-FLANGED,6X35	4
172	172BA0685	BOLT-STUD,6X85	2
214	214AA0510	SCREW-PAN+,-,5X10	1

This catalog covers:

FH541V- □ G80

09

This fig. covers:

AIR-FILTER/MUFFLER

E0190-B048A

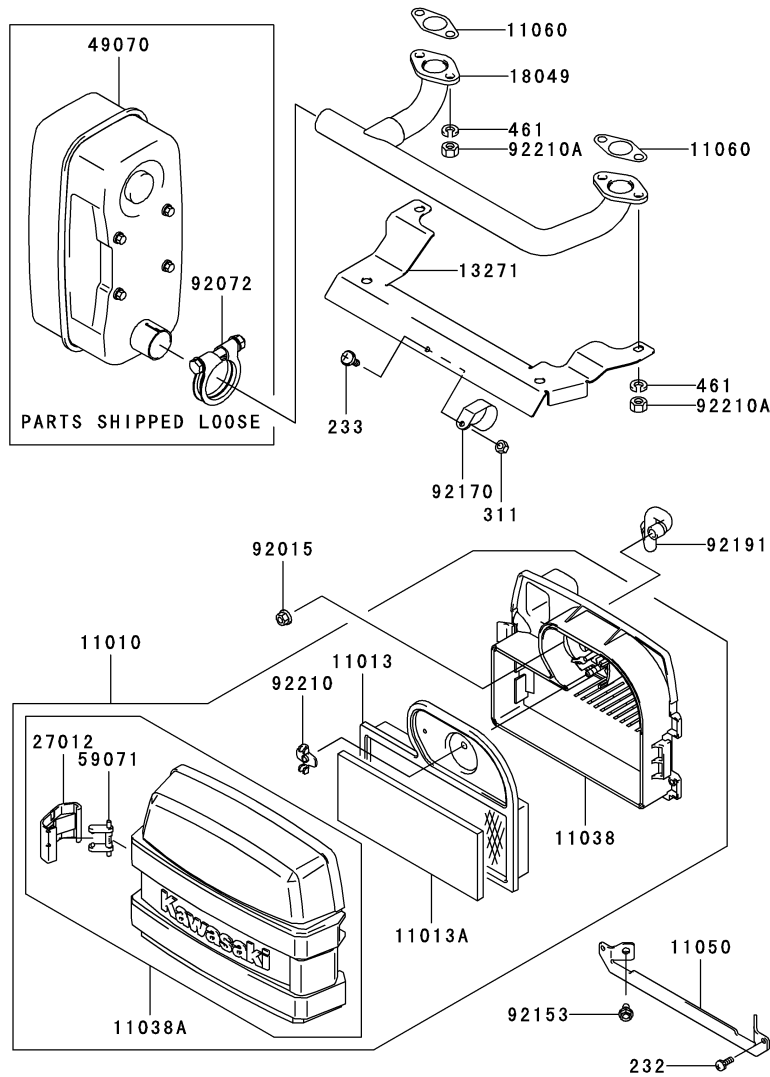

Ref. No.	Part No.	Description	Quantity
11010	11010-7013	FILTER-ASSY-AIR	1
11013	11013-7002	ELEMENT-AIR FILTER	1
11013A	11013-7033	ELEMENT-AIR FILTER	1
11038	11038-7006	CASE-ASSY-AIR FILTER	1
11038A	11038-7013	CASE-ASSY-AIR FILTER	1
11050	11050-7006	BRACKET	1
11060	11060-7021	GASKET,MUFFLER	2
13271	13271-7001	PLATE	1
18049	18049-7002	PIPE-EXHAUST	1
27012	27012-7003	HOOK	2
49070	49070-7008	MUFFLER-COMP	1
59071	59071-7017	JOINT	2
92015	92015-1193	NUT	2
92072	92072-7013	BAND	1
92153	92153-7043	BOLT,6X12	2
92170	92170-7002	CLAMP	1
92191	92191-7001	TUBE	1
92210	92210-7004	NUT	1
92210A	92210-7027	NUT,M8	4
232	232AA0514	SCREW-PAN-WS+,5X14	2
233	233AA0416	SCREW-PAN-WP+,4X16	1
311	311AA0400	NUT-HEX,4MM	1
461	461DA0800	WASHER-SPRING,8MM	4

This catalog covers:

FH541V- □ G80

10

This fig. covers:

FUEL-TANK/FUEL-VALVE

E0200-A551C

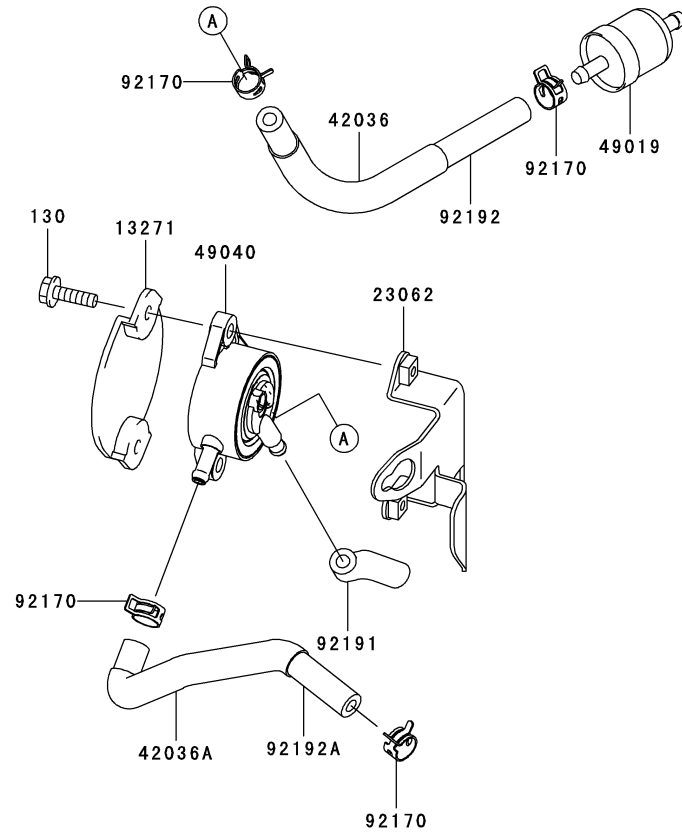

Ref. No.	Part No.	Description	Quantity
13271	13271-7004	PLATE	1
23062	23062-7019-9H	BRACKET-COMP	1
42036	42036-7008	SLEEVE	1
42036A	42036-7012	SLEEVE	1
49019	49019-7001	FILTER-FUEL	1
49040	49040-7001	PUMP-FUEL	1
92170	92170-2009	CLAMP	4
92191	92191-7002	TUBE	1
92192	92192-7135	TUBE,6.35X12.7X160	1
92192A	92192-7136	TUBE,6.35X12.7X180	1
130	130AA0620	BOLT-FLANGED,6X20	2

This catalog covers:

FH541V- □ **G80**

11

This fig. covers:

STARTER

E0210-A409A

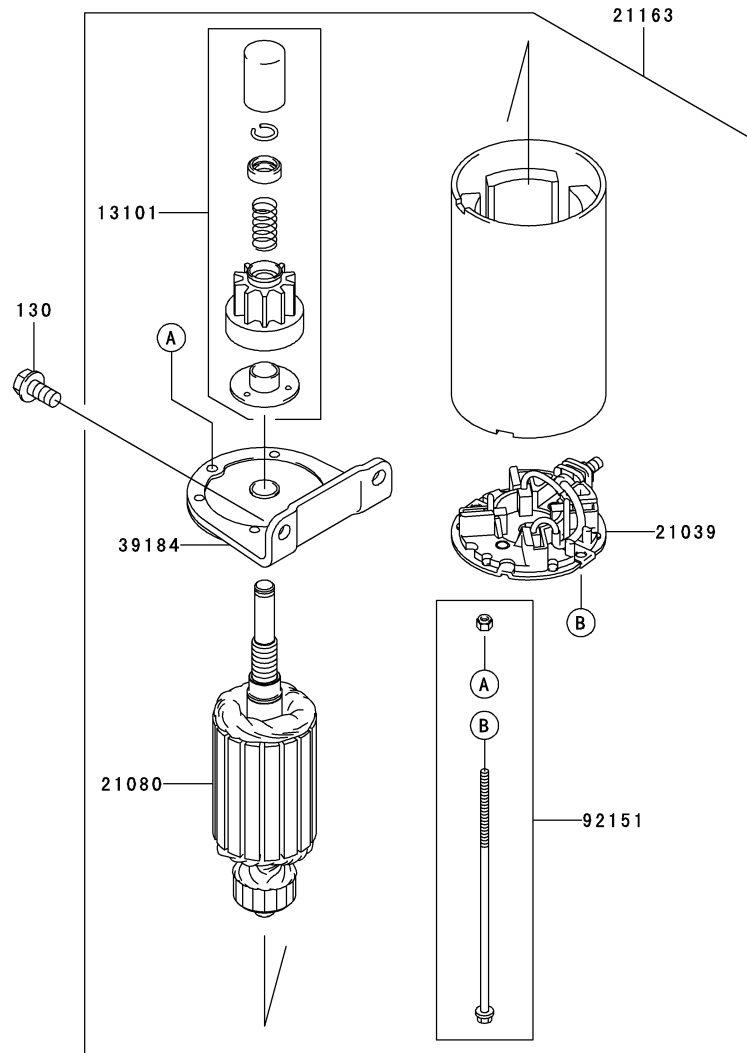

Ref. No.	Part No.	Description	Quantity
13101	13101-7003	GEAR-ASSY	1
21039	21039-7004	BRUSH	1
21080	21080-7005	ARMATURE	1
21163	21163-7022	STARTER-ELECTRIC	1
39184	39184-7004	BRACKET-ASSY	1
92151	92151-7013	BOLT	1
130	130AA0816	BOLT-FLANGED,8X16	2

This catalog covers:

FH541V- □ G80

12

This fig. covers:

LABEL

F0290-B426A

Ref. No.	Part No.	Description	Quantity
56070	56070-2014	LABEL-WARNING	1
56080	56080-7054	LABEL-BRAND	1

56070

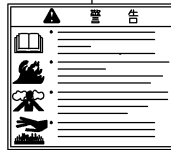

56080



This catalog covers:

FH541V- □ G80

This fig. covers:

PART NAME INDEX

AIR-FILTER/MUFFLER.....	09
CARBURETOR.....	08
CONTROL-EQUIPMENT.....	07
COOLING-EQUIPMENT.....	05
CYLINDER/CRANKCASE	01
ELECTRIC-EQUIPMENT.....	06
FUEL-TANK/FUEL-VALVE	10
LABEL.....	12
LUBRICATION-EQUIPMENT.....	04
PISTON/CRANKSHAFT	02
STARTER.....	11
VALVE/CAMSHAFT	03

This catalog covers:

FH541V- □ G80

This fig. covers:

NUMERICAL PARTS INDEX

Part No.	Fig No.	Part No.	Fig No.	Part No.	Fig No.	Part No.	Fig No.	Part No.	Fig No.
11004-7016	01	16025-7006	08	56070-2014	12	92153-7033	07		
11008-6043	01	16030-7003	08	56080-7054	12	92153-7043	01		
11008-7020	01	16031-7002	08	59031-7009	06	92153-7043	04		
11010-7013	09	16041-7016	08	59031-7014	06	92153-7043	05		
11013-7002	09	16041-7018	08	59041-7012	05	92153-7043	07		
11013-7033	09	16073-7007	08	59051-7011	04	92153-7043	09		
11022-7018	01	16154-2053	04	59066-7011	05	92153-7054	01		
11038-7006	09	16154-2054	04	59071-2079	01	92170-2009	10		
11038-7013	09	16169-7010	07	59071-7017	09	92170-7001	07		
11050-7006	09	16171-7001	07	59076-7001	08	92170-7002	09		
11060-7001	01	16186-7004	08	59076-7017	08	92172-7018	06		
11060-7008	01	172BA0685	08	59231-7005	04	92172-7029	05		
11060-7021	09	172BA0818	01	670D2016	04	92191-7001	09		
11061-7001	01	18049-7002	09	92009-2083	08	92191-7002	10		
11061-7004	08	21039-7004	11	92009-2308	06	92192-7135	10		
11061-7009	08	21066-7011	06	92009-2341	03	92192-7136	10		
11061-7010	08	21080-7005	11	92009-2349	08	92200-7001	03		
11061-7018	08	21163-7022	11	92009-7007	07	92200-7002	06		
11061-7019	08	21171-7034	06	92015-1193	09	92210-7004	09		
12004-7003	03	21188-7002	08	92015-2253	03	92210-7027	09		
12005-7003	03	21193-7032	06	92022-1982	02				
12009-7001	03	214AA0408	07	92026-7007	05				
12011-2056	03	214AA0510	08	92033-7001	03				
12016-7008	03	23062-7010	05	92033-7002	02				
12032-7001	03	23062-7019-9H	10	92033-7003	01				
13001-7010	02	232AA0514	09	92038-2101	02				
13002-7001	02	233AA0416	09	92043-7001	01				
13008-6060	02	26030-7001	06	92043-7003	04				
13031-7073	02	26031-7012	06	92049-7001	01				
13070-7001	03	27005-2056	06	92049-7005	01				
13070-7004	03	27008-2055	06	92049-7010	01				
130AA0616	05	27010-2154	06	92049-7011	01				
130AA0620	06	27012-7003	09	92063-7046	08				
130AA0620	10	311AA0400	09	92063-7047	08				
130AA0625	05	311AA0600	07	92063-7063	08				
130AA0635	08	39076-7001	08	92066-7002	01				
130AA0640	01	39129-7003	07	92066-7002	06				
130AA0816	05	39184-7004	11	92066-7003	04				
130AA0816	11	411AA0600	07	92070-7003	06				
130CA0875	01	42036-7008	10	92072-7003	06				
13101-7003	11	42036-7010	03	92072-7013	09				
13107-7009	04	42036-7012	10	92081-2234	08				
13107-7010	07	461DA0800	09	92093-2100	08				
13107-7018	08	49015-6253	01	92093-7003	08				
13116-2057	03	49019-7001	10	92140-7003	04				
13251-7010	02	49040-7001	10	92140-7005	03				
13270-7007	05	49065-2078	04	92145-7001	03				
13271-7001	09	49065-7004	04	92145-7002	04				
13271-7004	10	49070-7008	09	92145-7003	07				
13271-7007	03	49078-7001	03	92145-7004	07				
13271-7016	01	49089-7002	05	92145-7005	07				
13271-7017	04	49089-7032	05	92145-7015	08				
13271-7021	03	49089-7034	05	92150-2182	07				
13271-7032	07	49103-7004	07	92151-2097	06				
14037-7020-9H	05	49109-7002	01	92151-7010	02				
14075-7009	04	49113-7011	07	92151-7013	11				
14091-7006	01	49118-7004	03	92151-7017	02				
15003-7086	08	49120-7113	01	92153-7007	05				
16014-7007	08	49121-7007	08	92153-7008	05				
16020-7003	08	510A5100	06	92153-7019	03				