

パーツカタログ

4サイクル 空冷エンジン

FC150V

製品コード	備考
FC150V-EA00	芝刈機

川崎重工業株式会社

CYLINDER/CRANKCASE

E0110-2243A

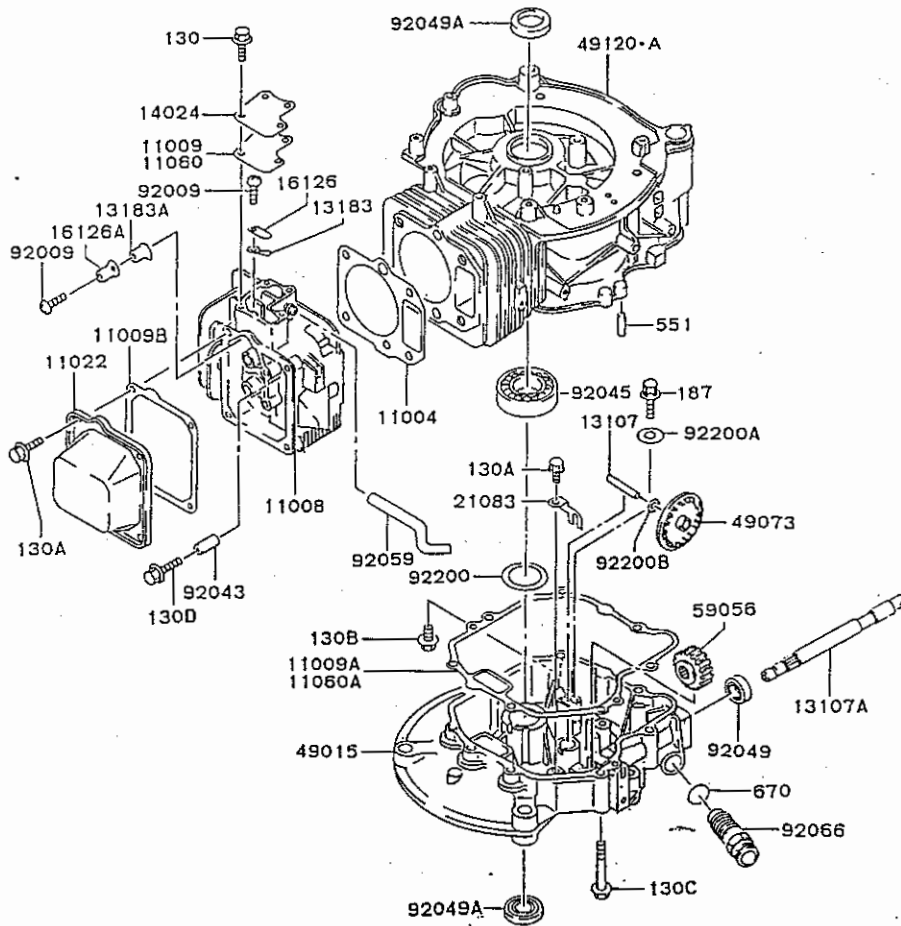

Ref. No.	Parts No.	Description	Quantity
11004	11004-2099	GASKET-HEAD	1
11008	11008-6008	HEAD-COMP-CYLINDER	1
11009	11009-2740	GASKET, COVER	1
	(FC150-B77966)		
11009A	11009-2770	GASKET, CRANKCASE COVER	1
	(FC150-B77966)		
11009B	11009-2848	GASKET, ROCKER CASE	1
11022	11022-2057	CASE-ROCKER	1
11060	11060-2007	GASKET, COVER	1
	(FC150-B77967)		
11060A	11060-2011	GASKET, CRANKCASE COVER	1
	(FC150-B77967)		
13107	13107-2202	SHAFT	1
13107A	13107-2227	SHAFT	1
13183	13183-2258	PLATE	1
13183A	13183-2259	PLATE	1
14024	14024-2180	COVER	1
16126	16126-2149	VALVE	1
16126A	16126-2150	VALVE	1
21083	21083-2062	ARM	1
49015	49015-6088	COVER-CRANKCASE	1
49073	49073-2055	SLINGER-OIL	1
49120	49120-2189	CRANKCASE-COMP	1
49120A	49120-2240	CRANKCASE-COMP	1
59056	59056-2790	GEAR-HELICAL	1
92009	92009-2166	SCREW, 5X8	2
92043	92043-1264	PIN	2
92045	92045-2155	BEARING-BALL	1
92049	92049-2204	SEAL-OIL	1
92049A	92049-2208	SEAL-OIL	2
92059	92059-2256	TUBE	1
92066	92066-2180	PLUG	1
92200	92200-2026	WASHER, 25X42X1.0	1
92200A	92200-2033	WASHER, 5X16X0.8	1
92200B	92200-2034	WASHER, 6X12X1.6	1
130	130B0510	BOLT-FLANGED	4
130A	130B0612	BOLT-FLANGED	5
130B	130G0625	BOLT-FLANGED	5
130C	130G0645	BOLT-FLANGED	2
130D	130G0845	BOLT-FLANGED	4

FC150V-□ A00

1 - CYLINDER/CRANKCASE

E0110-2243A

Ref. No.	Parts No.	Description	Quantity
187	187B0510	BOLT-UPSET-WSP	1
551	551A0612	PIN-DOWEL	2
670	670D2015	O RING	1

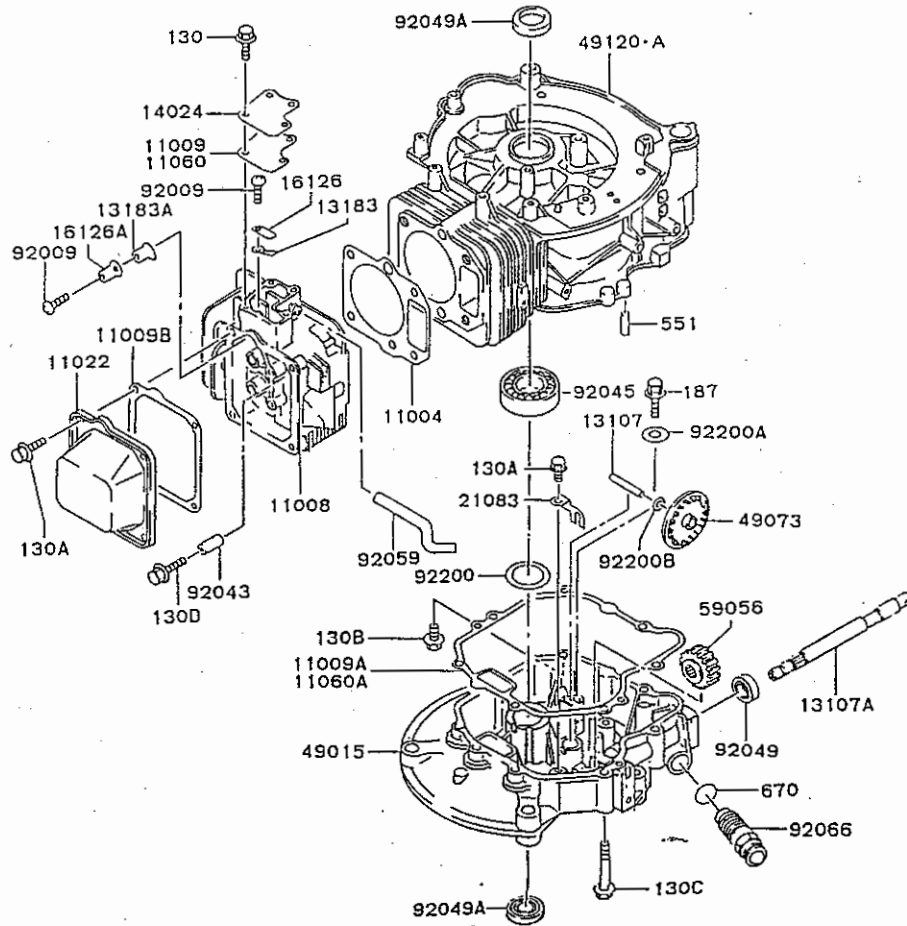

2 PISTON/CRANKSHAFT

E0120-2002A

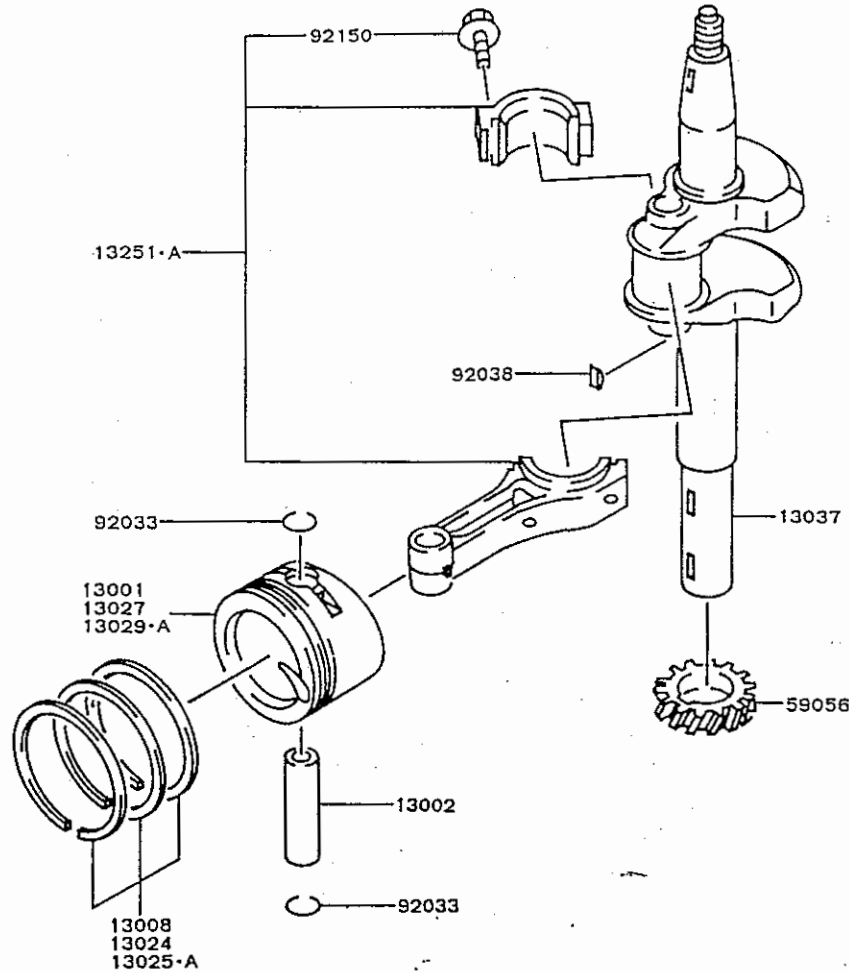

Ref. No.	Parts No.	Description	Quantity
13001	13001-2109	PISTON-ENGINE	1
13002	13002-2074	PIN-PISTON	1
13008	13008-6017	RING-SET-PISTON	1
13024	13024-6002	RING-SET-PISTON LL,0.75	AR
13025	13025-6003	RING-SET-PISTON L,0.25	AR
13025A	13025-6004	RING-SET-PISTON L,0.50	AR
13027	13027-2058	PISTON-ENGINE LL,0.75	AR
13029	13029-2094	PISTON-ENGINE L,0.25	AR
13029A	13029-2095	PISTON-ENGINE L,0.50	AR
13037	13037-2359	CRANKSHAFT	1
13251	13251-6025	ROD-ASSY-CONNECTING	1
13251A	13251-6027	ROD-ASSY-CONNECTING,0.50	AR
59056	59056-2726	GEAR-HELICAL	1
92033	92033-2161	RING-SNAP	2
92038	92038-2093	KEY	1
92150	92150-2122	BOLT,CONNECTING ROD	2

VALVE/CAMSHAFT

E0130-2029D

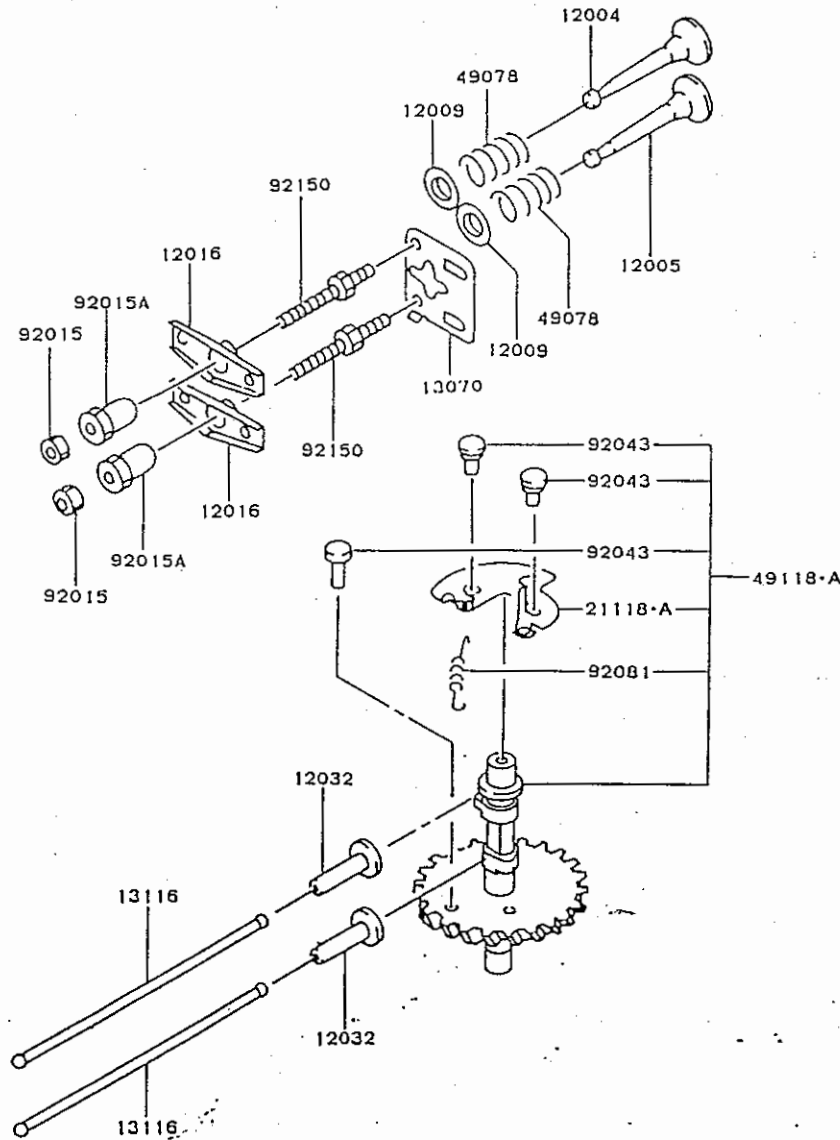

Ref. No.	Parts No.	Description	Quantity
12004	12004-2090	VALVE-INTAKE	1
12005	12005-2074	VALVE-EXHAUST	1
12009	12009-2062	RETAINER-VALVE SPRING	2
12016	12016-2057	ARM-ROCKER	2
12032	12032-2065	TAPPET	2
13070	13070-2072	GUIDE	1
13116	13116-2065	ROD-PUSH	2
21118	21118-2069	DECOMPRESSOR	1
	(FC150-B74380)		
21118A	21118-2082	DECOMPRESSOR	1
	(FC150-B74381 -)		
49078	49078-2064	SPRING-ENGINE VALVE	2
49118	49118-2068	CAMSHAFT-COMP	*
49118A	49118-2095	CAMSHAFT-COMP	1
92015	92015-2240	NUT	2
92015A	92015-2253	NUT	2
92043	92043-2168	PIN	3
92081	92081-2342	SPRING	1
92150	92150-2102	BOLT	2

LUBRICATION-EQUIPMENT

E0140-2045A

Ref. No.	Parts No.	Description	E	Quantity
11009	11009-2346	GASKET, OIL GAUGE	1	1
13070	13070-2078	GUIDE	1	1
52005	52005-2094	GAUGE, OIL	1	1
59231	59231-2071	FILLER	1	1
670	670D2016	O RING	1	1

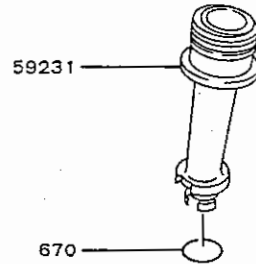
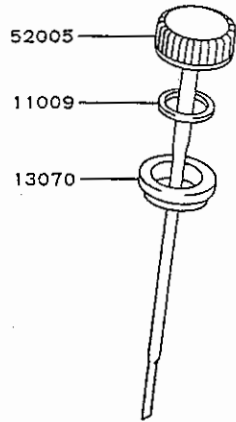

COOLING-EQUIPMENT

E0150-2075G

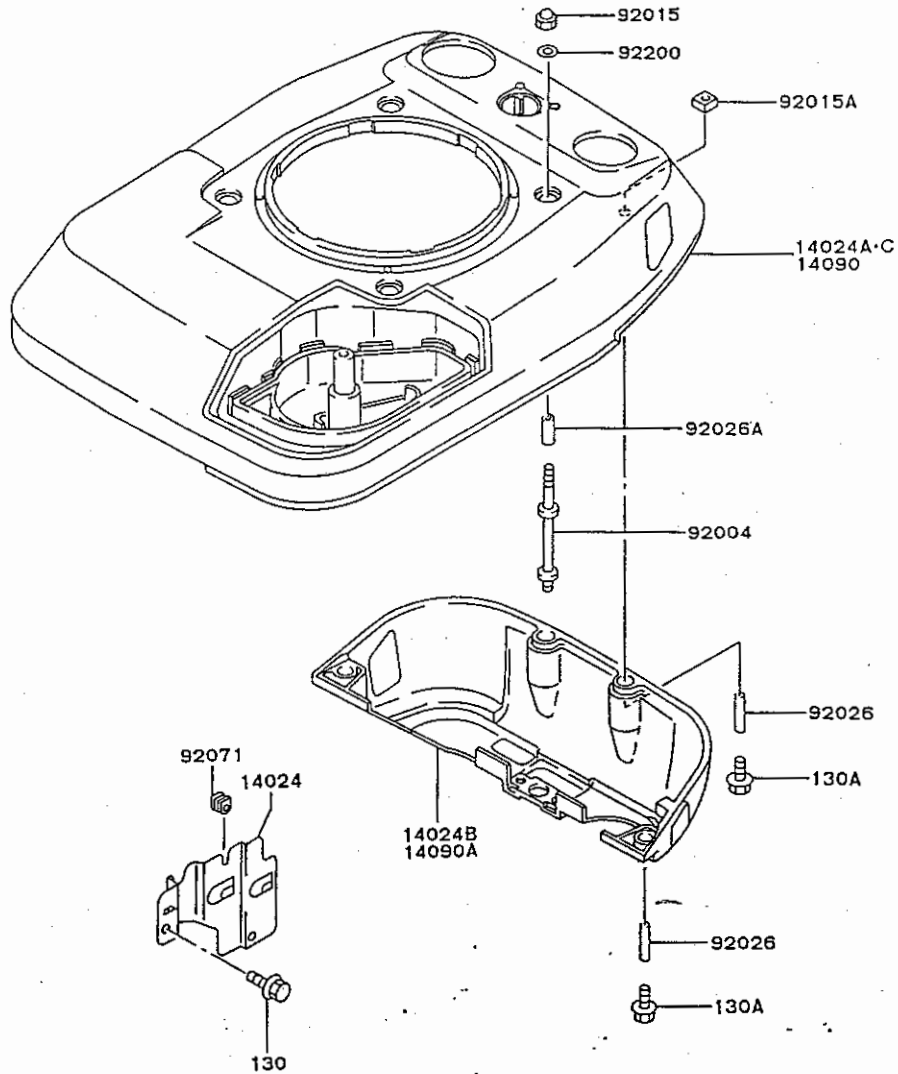

Ref. No.	Parts No.	Description	Quantity
14024	14024-2181	COVER	1
14024A	14024-2231	COVER, UPPER	1
	(FC150-B19327)		
14024B	14024-2232	COVER, LOWER	*
14024C	14024-2287	COVER, UPPER	*
	(FC150-B19328 -)		
14090	14090-2007	COVER, UPPER	1
14090A	14090-2011	COVER, LOWER	1
92004	92004-2117	STUD	4
92015	92015-1170	NUT	4
92015A	92015-2241	NUT, 6MM	4
92026	92026-2273	SPACER, 6.2X7.8X17	4
92026A	92026-2274	SPACER, 6.2X7.8X22	4
92071	92071-2113	GROMMET	1
92200	92200-2037	WASHER, 6.5X18X2.0	4
130	130B0510	BOLT-FLANGED	2
130A	130G0625	BOLT-FLANGED	4

ELECTRIC-EQUIPMENT

E0160-2424B

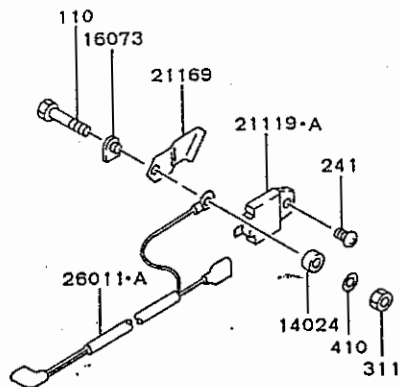
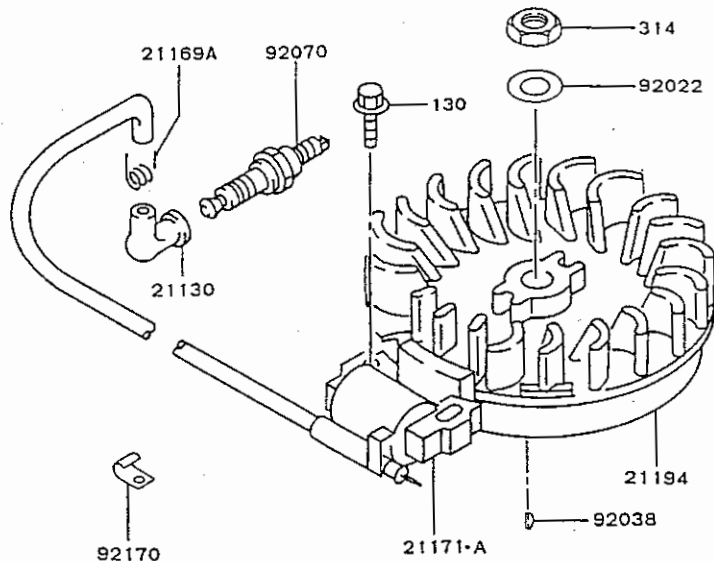

Ref. No.	Parts No.	Description	Quantity
14024	14024-2183	COVER	1
16073	16073-2124	INSULATOR	1
21119	21119-2119	IGNITER	1
	(FC150-B50812)		
21119A	21119-2139	IGNITER	1
	(FC150-B50813 -)		
21130	21130-2066	CAP-SPARK PLUG	1
21169	21169-2066	TERMINAL	1
21169A	317270-8419A	TERMINAL	1
21171	21171-2153	COIL-ASSY-IGNITION	1
	(FC150-B50812)		
21171A	21171-2176	COIL-ASSY-IGNITION	1
	(FC150-B50813 -)		
21194	21194-2218	FLYWHEEL-COMP	1
26011	26011-2246	WIRE-LEAD	1
26011A	26011-2279	WIRE-LEAD	1
92022	314401-3482A	WASHER	1
92038	92038-2077	KEY	1
92070	92070-2081	PLUG-SPARK, BP6ES (NGK)	1
92170	92170-2041	CLAMP	1
110	110B0522	BOLT-FLANGED	1
130	130G0625	BOLT-FLANGED	2
241	241B0412	SCREW-PAN-WP+-	1
311	311B0500	NUT-HEX	1
314	314G1400	NUT-HEX-FINE	1
410	410B0500	W-PLAIN-S	1

This catalog covers:
FC150V-□ B02

06

This fig. covers:
ELECTRIC-EQUIPMENT

E0160-A287A

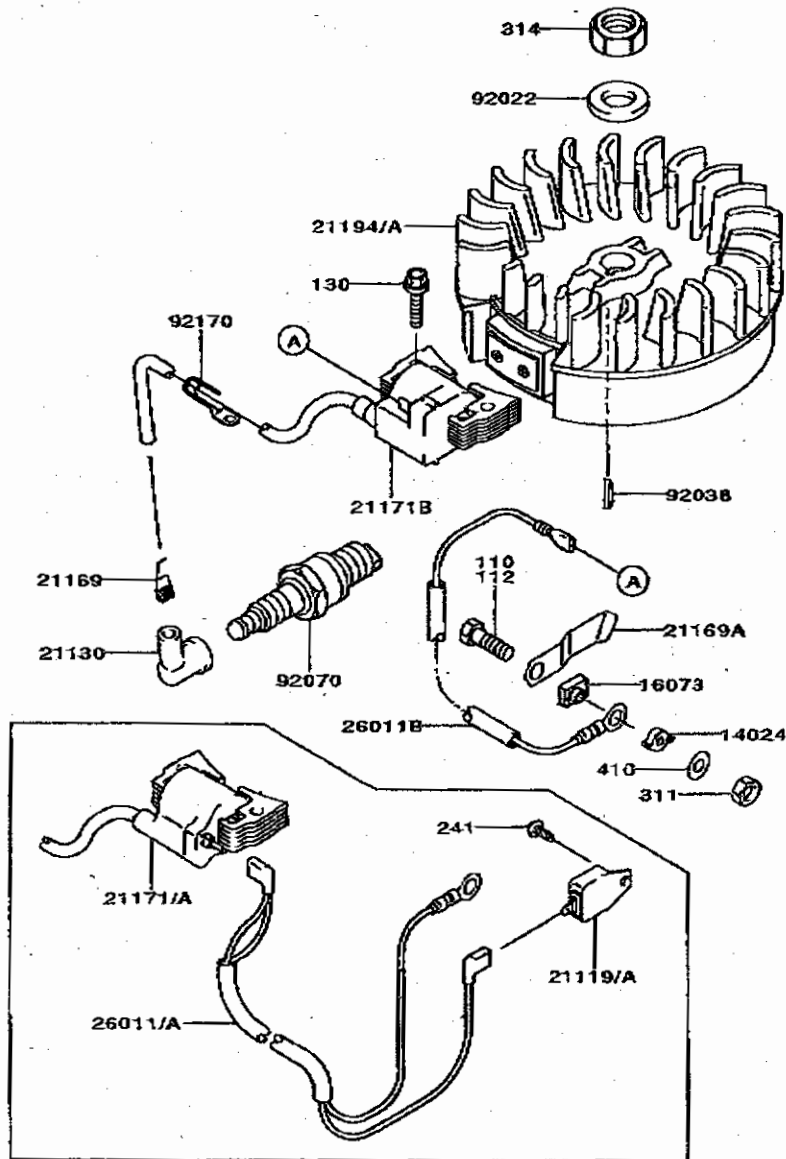

Ref. No.	Parts No.	Description	Quantity
14024	14024-2183	COVER	1
16073	16073-2124	INSULATOR	1
21119	21119-2119	IGNITER	1
21119A	21119-2139	IGNITER FC150-B50811)	1
21130	21130-2066	CAP-SPARK PLUG	1
21169	21169-2004	TERMINAL	1
21169A	21169-2066	TERMINAL	1
21171	21171-2153	COIL-ASSY-IGNITION	1
21171A	21171-2176	COIL-ASSY-IGNITION FC150-B50812-	1
21171B	21171-2200	COIL-ASSY-IGNITION	1
21194	21194-2218	FLYWHEEL-COMP	1
21194A	21194-2290	FLYWHEEL-COMP	1
26011	26011-2246	WIRE-LEAD	1
26011A	26011-2279	WIRE-LEAD FC150-C13448-	1
26011B	26011-2306	WIRE-LEAD	1
92022	92022-2102	WASHER	1
92038	92038-2077	KEY	1
92070	92070-2084	PLUG-SPARK, BP8ES(NGK)	1
92170	92170-2041	CLAMP	1
110	110B0522	BOLT-FLANGED	1
112	112B0522	BOLT-UPSET	1
130	130G0625	BOLT-FLANGED	2
241	241B0412	SCREW-PAN-WP+	1
311	311B0500	NUT-HEX	1
314	314G1400	NUT-HEX-FINE	1
410	410B0500	W-PLAIN-S	1

E0170-2068E

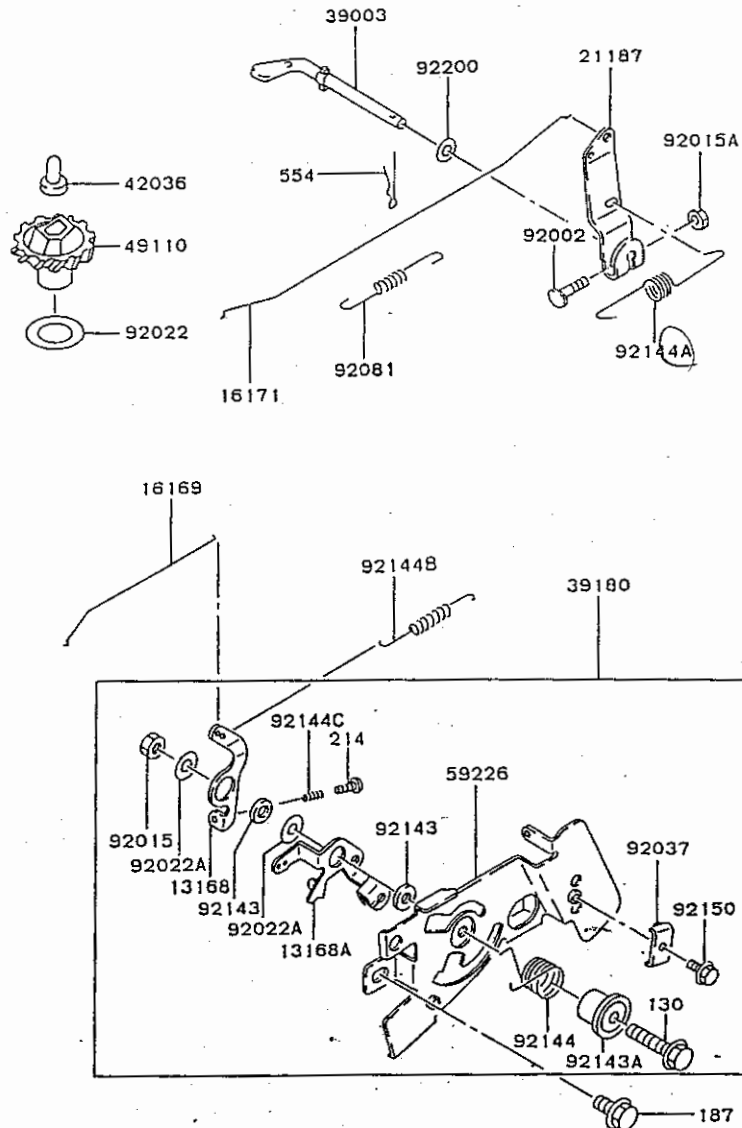

Ref. No.	Parts No.	Description	Quantity
13168	13168-2288	LEVER	1
13168A	13168-2298	LEVER	1
16169	16169-2104	LINK-CHOKE	1
16171	16171-2060	LINK	1
21187	21187-2060	ARM-ASSY	1
39003	39003-2071	ARM-PIVOT	1
39180	39180-2549	PANEL-ASSY-CONTROL	1
42036	314401-5121B	SLEEVE	1
49110	49110-2076	GOVERNOR-ASSY	1
59226	59226-2201	PANEL-CONTROL	1
92002	92002-2269	BOLT	1
92015	314401-5385A	NUT	1
92015A	92015-1193	NUT	1
92022	314401-5135A	WASHER	1
92022A	92022-2372	WASHER, 6X19X1.2	2
92037	92037-2209	CLAMP	1
92081	92081-2299	SPRING, LINK	1
92143	92143-2135	COLLAR, 6X13X2.3	2
92143A	92143-2148	COLLAR	1
92144	92144-2211	SPRING	1
92144A	92144-2213	SPRING	1
92144B	92144-2235	SPRING	1
92144C	92144-2266	SPRING	1
92150	92150-2182	BOLT, 5X18	1
92200	92200-2029	WASHER, 6.5X11.5X2.0	1
130	130B0630	BOLT-FLANGED	1
187	187B0614	BOLT-UPSET-WSP	2
214	214B0420	SCREW-PAN+-	1
554	554A0600	PIN-SNAP	1

E0180-2202J

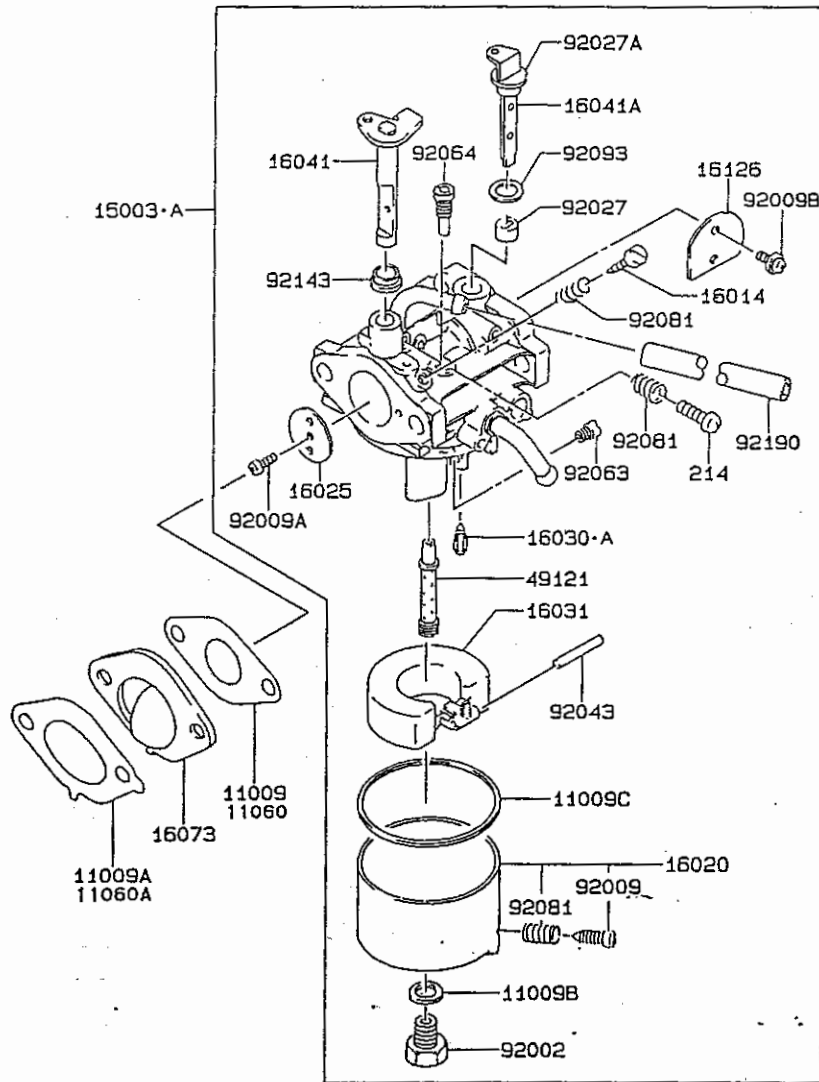

Ref. No.	Parts No.	Description	Quantity
11009	11009-2746	GASKET, CARBURETOR	1
	(FC150-B77966)		
11009A	11009-2833	GASKET, INSULATOR	1
	(FC150-B77966)		
11009B	314499-6159A	GASKET	1
11009C	314598-6128A	GASKET	1
11060	11060-2010	GASKET, CARBURETOR	1
	(FC150-B77967)		
11060A	11060-2012	GASKET, INSULATOR	1
	(FC150-B77967)		
15003	15003-2006	CARBURETOR-ASSY	*
15003A	15003-2088	CARBURETOR-ASSY	1
16014	316470-6114-00	SCREW-PILOT AIR	1
16020	314576-6130A	CHAMBER-FLOAT	1
16025	313650-6101-00	VALVE-THROTTLE, #110	1
16030	16030-2083	VALVE-FLOAT	1
16030A	314499-6122A	VALVE-FLOAT	*
16031	16031-2058	FLOAT	1
16041	16041-2178	SHAFT-CARBURETOR, THROTTLE	1
16041A	16041-2197	SHAFT-CARBURETOR, CHOKE	1
16073	16073-2136	INSULATOR	1
16126	16126-2173	VALVE, CHOKE	1
49121	49121-2113	NOZZLE-MAIN, #2A	1
92002	314499-6143A	BOLT	1
92009	315470-6133A	SCREW	1
92009A	316550-6137A	SCREW	1
92009B	92009-2149	SCREW	2
92027	314598-6138A	COLLAR	1
92027A	314598-6157A	COLLAR	1
92043	314499-6127A	PIN	1
92063	92063-2096	JET-MAIN, #68.8	1
92064	92064-2065	JET-PILOT, #38.8	1
92081	313122-6116-00	SPRING	3
92093	92093-2087	SEAL	1
92143	92143-2143	COLLAR	1
92190	92190-2003	TUBE, 5X8X125	1
214	214B0412	SCREW-PAN+-	1

AIR-FILTER/MUFFLER

E0190-2278H

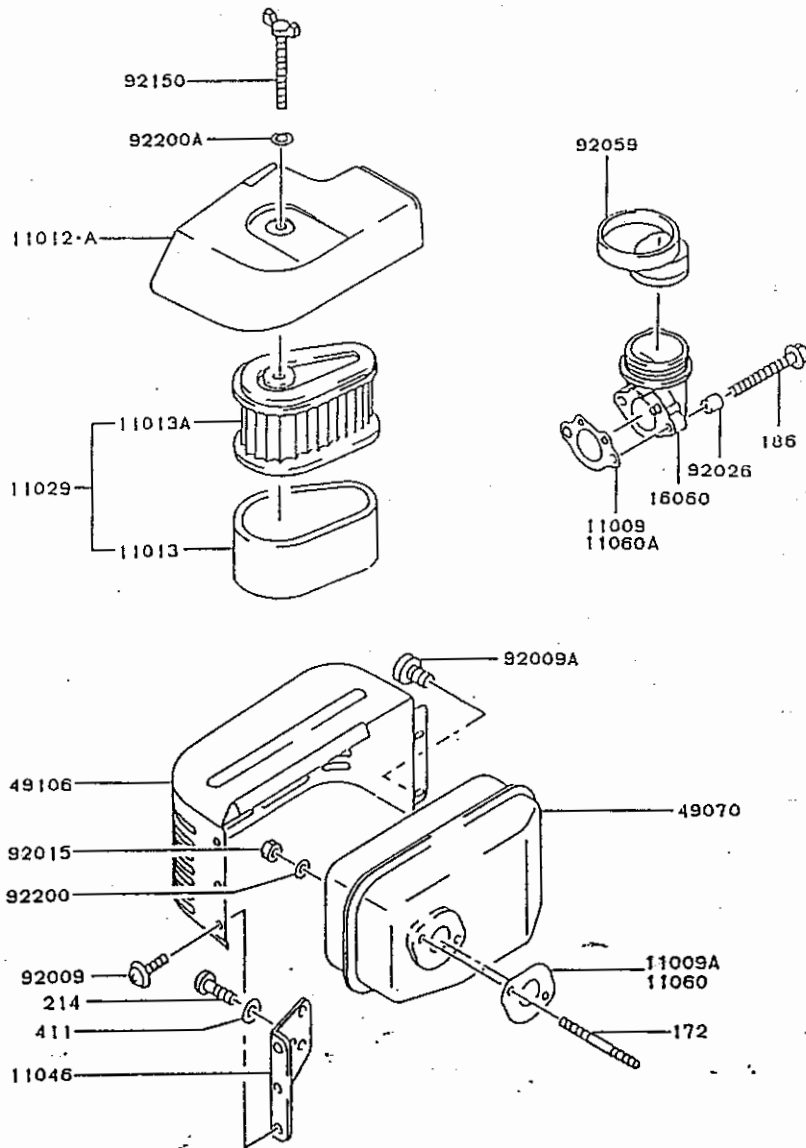

Ref. No.	Parts No.	Description	Quantity
11009	11009-2742	GASKET, INTAKE PIPE - FC150-B77966)	1
11009A	11009-2743	GASKET, MUFFLER	*
11012	11012-2264	CAP, AIR FILTER	*
11012A	11012-2311	CAP, AIR FILTER	1
11013	11013-2119	ELEMENT-AIR FILTER	1
11013A	11013-2120	ELEMENT-AIR FILTER	1
11029	11029-2002	ELEMENT-ASSY-AIR FILTER	1
11046	11046-2053	BRACKET	1
11060	11060-2009	GASKET, MUFFLER	1
11060A	11060-2067 (FC150-B77967)	GASKET, INTAKE PIPE	1
16060	16060-2129	PIPE-INTAKE	1
49070	49070-2461	MUFFLER-COMP	1
49106	49106-2430	COVER-MUFFLER	1
92009	92009-2166	SCREW, 5X8	3
92009A	92009-2308	SCREW	2
92015	92015-1193	NUT	2
92026	92026-2272	SPACER, 6.2X7.8X8	2
92059	92059-2257	TUBE	1
92150	92150-2101	BOLT	1
92200	92200-2032	WASHER, 7X21X2.3	2
92200A	92200-2037	WASHER, 6.5X18X2.0	1
172	172G0680	BOLT-STUD	2
186	186B0680	BOLT-UPSET-WP	2
214	214B0510	SCREW-PAN+-	2
411	411B0500	WASHER-PLAIN	2

FUEL-TANK/FUEL-VALVE

E0200-2241C

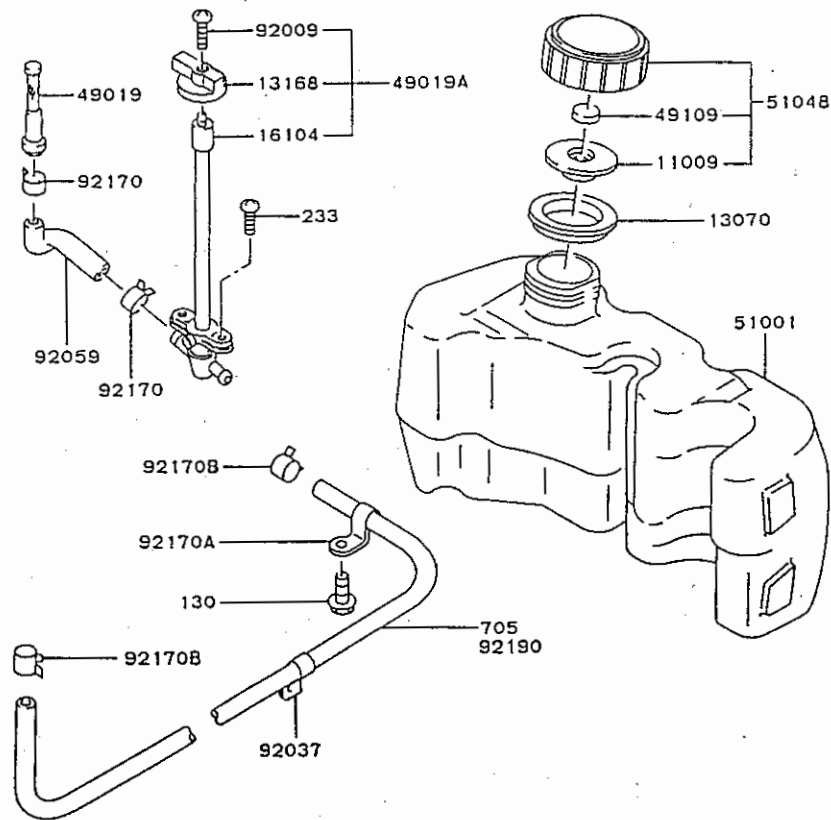

Ref. No.	Parts No.	Description	Quantity
11009	11009-2831	GASKET	1
13070	13070-2077	GUIDE	1
13168	13168-2303	LEVER	1
16104	16104-2052	FILTER-COMP	1
49019	49019-2091	FILTER-FUEL	1
49019A	49019-2094	FILTER-FUEL	1
49109	49109-2054	ELEMENT-BREATHER	1
51001	51001-2214	TANK-COMP-FUEL	1
51048	51048-2069	CAP-ASSY-TANK	1
92009	92009-2296	SCREW	1
92037	92037-2202	CLAMP	1
92059	92059-2262	TUBE	1
92170	92170-2009	CLAMP	2
92170A	92170-2037	CLAMP	1
92170B	92170-2043	CLAMP	2
92190	92190-2068	TUBE, 4.8X10.3X425	1
130	130B0612	BOLT-FLANGED	2
233	233B0510	SCREW-PAN-WP+-	2
705	705A041000	TUBE-BRAID, L=425MM	*

STARTER

E0210-2003A

Ref. No.	Parts No.	Description	Quantity
11012	11012-2255	CAP, GRIP	1
13070	13070-2064	GUIDE, ROPE	1
13091	13091-2113	HOLDER, RECOIL	1
13165	13165-2072	PAWL, RECOIL STARTER	1
39108	39108-2059	RETAINER-SPRING	1
46075	46075-2082	GRIP, RECOIL STARTER	1
49080	49080-2143	PULLEY-STARTING	1
49088	49088-2379	STARTER-RECOIL	1
59101	59101-2079	REEL, RECOIL STARTER	1
59106	59106-2115	ROPE, 3.8X1600	1
92009	92009-2280	SCREW, 5X18	1
92022	92022-2384	WASHER, 5X12.8X1.2	1
92081	315601-3452A	SPRING, RECOIL	1
92144	92144-2176	SPRING	1
92144A	92144-2177	SPRING, RETURN	1

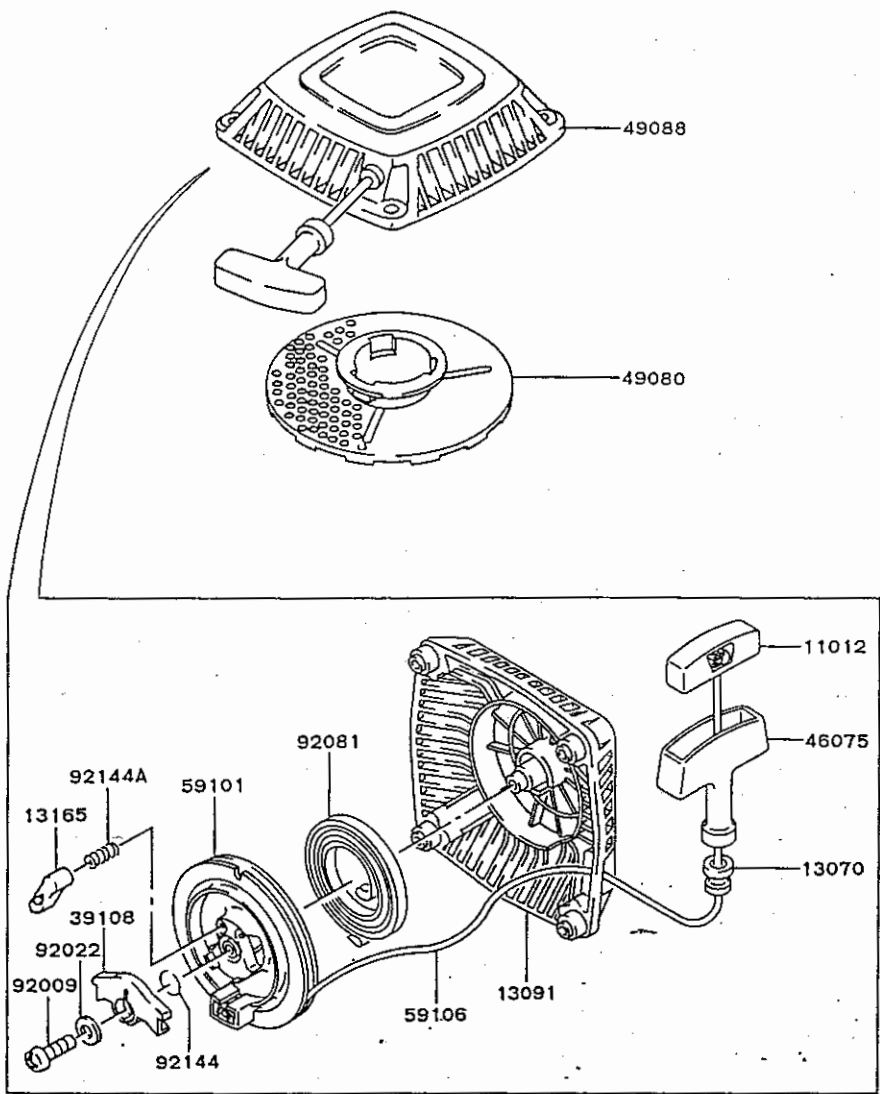

F0290-2106A

Ref. No.	Parts No.	Description	Quantity
56031	56031-2375	LABEL-MANUAL	1
56031A	56031-2376	LABEL-MANUAL	1
56038	56038-2542	LABEL-BRAND	1

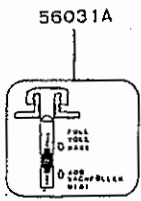

56031

AIR CLEANER MAINTENANCE	LUFTFILTER-PFLEGE	ENTRETIEN DU FILTRE À AIR
<p>FOAM</p> <p>ELEMENTS CLEAN EVERY 25 HRS.</p> <p>1. WASH IN DETERGENT AND WATER AND DRY THOROUGHLY.</p> <p>2. SATURATE IN ENGINE OIL AND SQUEEZE OUT EXCESS.</p> <p>PAPER</p> <p>ELEMENTS CLEAN EVERY 100 HRS:</p> <p>1. CLEAN BY TAPPING GENTLY TO REMOVE DIRT.</p> <p>2. IF VERY DIRTY, REPLACE OR WASH IN DETERGENT AND WATER AND DRY THOROUGHLY.</p>	<p>REINIGEN SIE DAS SCHÄUMLEBENT JEWEILS NACH 25 UHREN LAUFZEIT.</p> <p>1. WASCHEN SIE ES MIT REINIGUNGSMITTEL UND WASSER UND TROCKNEN SIE ES SORGFÄLTIG.</p> <p>2. TRÄNKEN-SIE ES IN MOTORÖL UND DRÜCKEN ÜBERSCHÜSSIGES ÖL AUS. REINIGEN SIE DAS PAPIERLEBENT JEWEILS NACH 100 STUNDEN.</p> <p>3. ENTFERNEN SIE DEN STAUB VORSICHTIG.</p> <p>4. EIN STARK VERSCHMUTZTES PAPIER-ELEMENT ZUSÄTZLICH SIE REINIGEN ODER ERSETZEN ES MIT NEUEM.</p> <p>5. WENN SEHR SEHR VERSCHMUTZT UND WASSER UND PROZESSEN ES ABSCHLIESSEN SORGFÄLTIG.</p>	<p>NETTOYER LA MOUSSE-TOUTES LES 25 H.</p> <p>1. LAVER À L'EAU SAVONNEUSE, RINCER ET TROCHER.</p> <p>2. IMBIBER LÉGÈREMENT AVEC DE L'HUILE MOTEUR.</p> <p>NETTOYER LA CARTOUCHE SÈCHE TOUTES LES 100 H.</p> <p>3. TAPER LÉGÈREMENT LA CARTOUCHE POUR ÉVACUER LES POUSSIÈRES.</p> <p>4. EN CAS DE DÉPÔTS TRÈS IMPORTANTS, REMPLACER LA CARTOUCHE.</p>