

*This catalog covers:*  
**FS691V-AG80**

*This fig. covers:*  
**TITLE**

# PARTS CATALOG

## 4-STROKE ENGINE

### FS691V

PRODUCT CODE	NOTE
FS691V-AG80	RIDING MOWER (RM982F)

## PARTS CATALOG INTRODUCTION

This parts catalog lists parts and sub-assemblies provided as service parts.

When it becomes necessary to replace parts, always use KAWASAKI GENUINE PARTS which have passed strict inspection which guarantees quality and performance.

### 1. HOW TO ORDER PARTS

- When ordering the parts, be sure to use the parts catalog corresponding to the product code. Check the product revision codes on the product and the catalog.  
Product Code (example) : FA130D-**AA00**  
Product Revision Code
- Specify the part code (all digits) exactly as listed in this catalog on your parts order.
- The parts not shown in the illustrations of this catalog are not sold separately; only the complete units or next higher assemblies illustrated are supplied as the service parts.

### 2. EXPLANATION OF PARTS CATALOG FORMAT

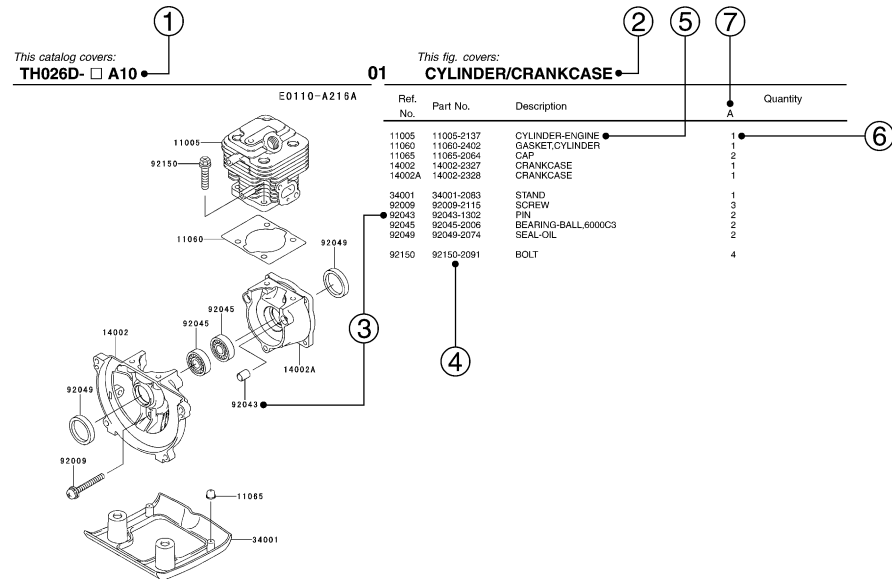

#### 1) Product Code

This code describes the product code covered by this catalog. The product revision code, which is a part of the product code, is omitted.

#### 2) Part Group Title

This title is the representative name for the group of parts illustrated on the page.

#### 3) Reference Number

The reference numbers are shown on the illustration and the list as the link between them.

## PARTS LIST INFORMATION

### 4) Part Number

This is the key of your parts ordering.

Three kinds of part number are used in this catalog.

#### a. Structure 1

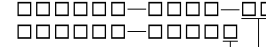

Part Revision Code

#### b. Structure 2

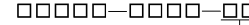

Color Code for Painted Part

#### c. Standard Hardware Number

(for bolts, nuts, washer, or the like)



Size Code

Material and Surface Treatment Code

Item Code

### 5) Description and Additional Information

The part name, the location, the size, and the serial number as additional information, etc. are described here. Use them to find out and check the part required.

When a part number is changed without change of the product revision code and the changed parts are not interchangeable, the serial number of the product is noted as follows;

- ( FA130 - 100001 ) : Affected units are from beginning of the product of the product code up to and including this serial number.
- ( FA130 - 100002 - ) : Affected units are from this serial number and above.
- ( FA130 - 100002 - FA130 - 110001 ) : Affected units are in this serial number range.

### 6) Quantity

The figure shows quantity of the part required at the indicated position on the illustration and for the specified product revision code.

The asterisk (\*) on this column means the part can be used as the substitute on the product and is supplied until the stock is exhausted.

Note:Some small parts will be supplied by units.

Example: If six (6) bolts are ordered and the minimum quantity per unit is five (5), two (2), units of the bolt will be delivered.

### 7) Product Revision Code

This Code indicates an important change which affects the service parts interchangeability.

### 3. ABBREVIATIONS

# .....	Number	FR.....	Front	RH .....	Right Hand
&.....	And	G .....	Gram	RPM ...	Revolutions Per Minute
(+)	Plus	HEX.....	Hexagonal	RR .....	Rear
(-)	Minus	ID=.....	Inside Diameter	STD.....	Standard
2ND.....	Second	IN.....	Inch	T.....	Teeth
3RD .....	Third	L=.....	Length	T=.....	Thickness
4TH.....	Fourth	LH.....	Left Hand	U/S.....	Under Size
A.....	Ampere	LWR .....	Lower	UPP .....	Upper
AR.....	As Required	MM.....	Millimeter	V.....	Volt
ASSY.....	Assembly	O/S.....	Over Size	W.....	Watt
CNT .....	Center	OD=.....	Outside Diameter		
COMP.....	Complete	REF.....	Reference		

This catalog covers:  
**FS691V- AG80**

This fig. covers:  
**01 CYLINDER/CRANKCASE**

E0110-A940A

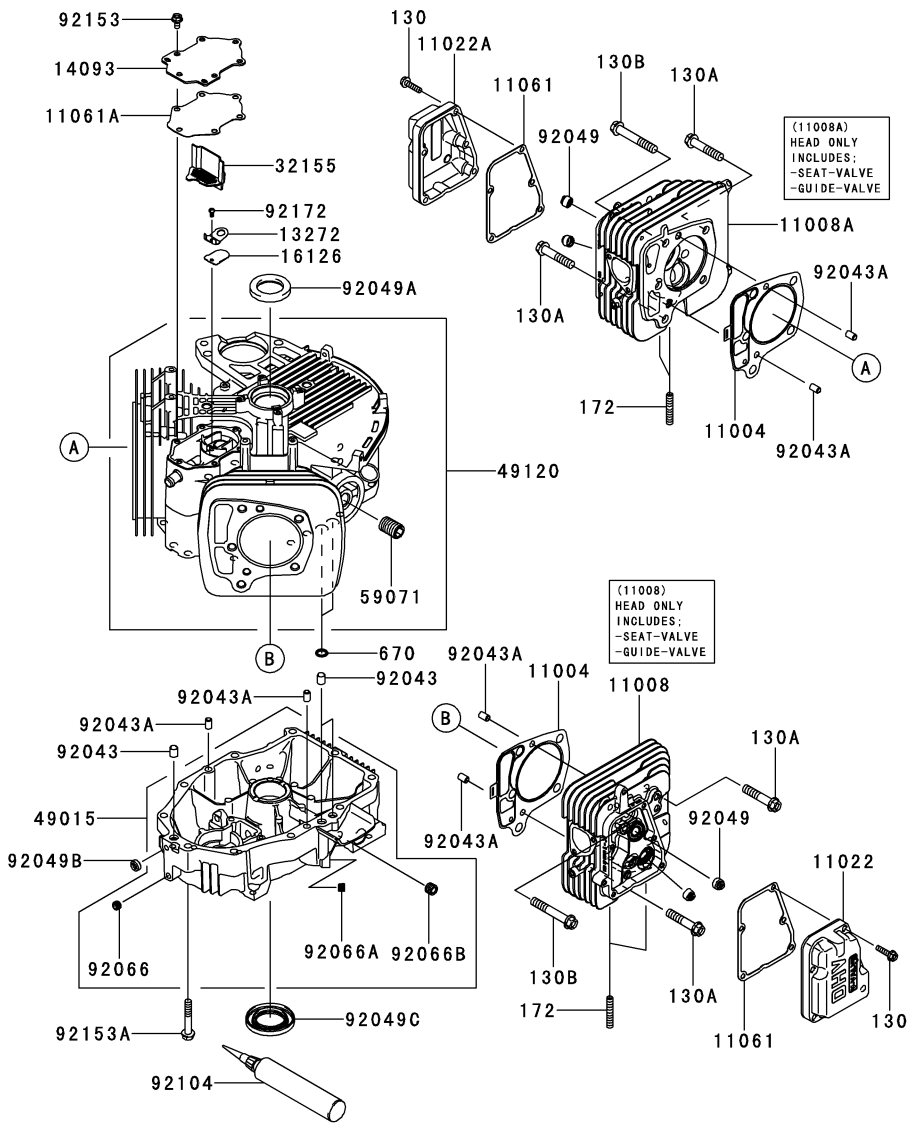

Ref. No.	Part No.	Description	Quantity
11004	11004-7026	GASKET-HEAD	2
11008	11008-0845	HEAD-COMP-CYLINDER,#2	1
11008A	11008-0861	HEAD-COMP-CYLINDER,#1	1
11022	11022-0038	CASE-ROCKER,#2	1
11022A	11022-0710	CASE-ROCKER,#1	1
11061	11061-7083	GASKET,CASE-ROCKER	2
11061A	11061-7094	GASKET,BREATHER	1
13272	13272-1374	PLATE	1
14093	14093-0455	COVER,BREATHER	1
16126	16126-7020	VALVE,BREATHER	1
32155	32155-7003	PIPE,BREATHER	1
49015	49015-0023	COVER-CRANKCASE	1
49120	49120-0858	CRANKCASE-COMP	1
59071	59071-0733	JOINT	1
92043	92043-0858	PIN	3
92043A	92043-1263	PIN,6.2X8X14	6
92049	92049-7001	SEAL-OIL,RVC2 6X11X10.2	4
92049A	92049-7010	SEAL-OIL,SD 35X48X8 R HS	1
92049B	92049-7019	SEAL-OIL,SO 8X14X5 HS	1
92049C	92049-7028	SEAL-OIL,38X62X8MTCLV	1
92066	92066-0761	PLUG	1
92066A	92066-0762	PLUG	1
92066B	92066-2223	PLUG	1
92104	92104-0007	GASKET-LIQUID,TB1217H	AR
92153	92153-7043	BOLT,6X12	6
92153A	92153-7054	BOLT,8X50	10
92172	92172-0870	SCREW,4X8	1
130	130BA0625	BOLT-FLANGED,6X25	10
130A	130CA1050	BOLT-FLANGED,10X50	4
130B	130CA1065	BOLT-FLANGED,10X65	6
172	172BA0822	BOLT-STUD,8X22	4
670	670B2011	O RING,11MM	2

This catalog covers:  
**FS691V- AG80**

This fig. covers:  
**02 PISTON/CRANKSHAFT**

E0120-A557B

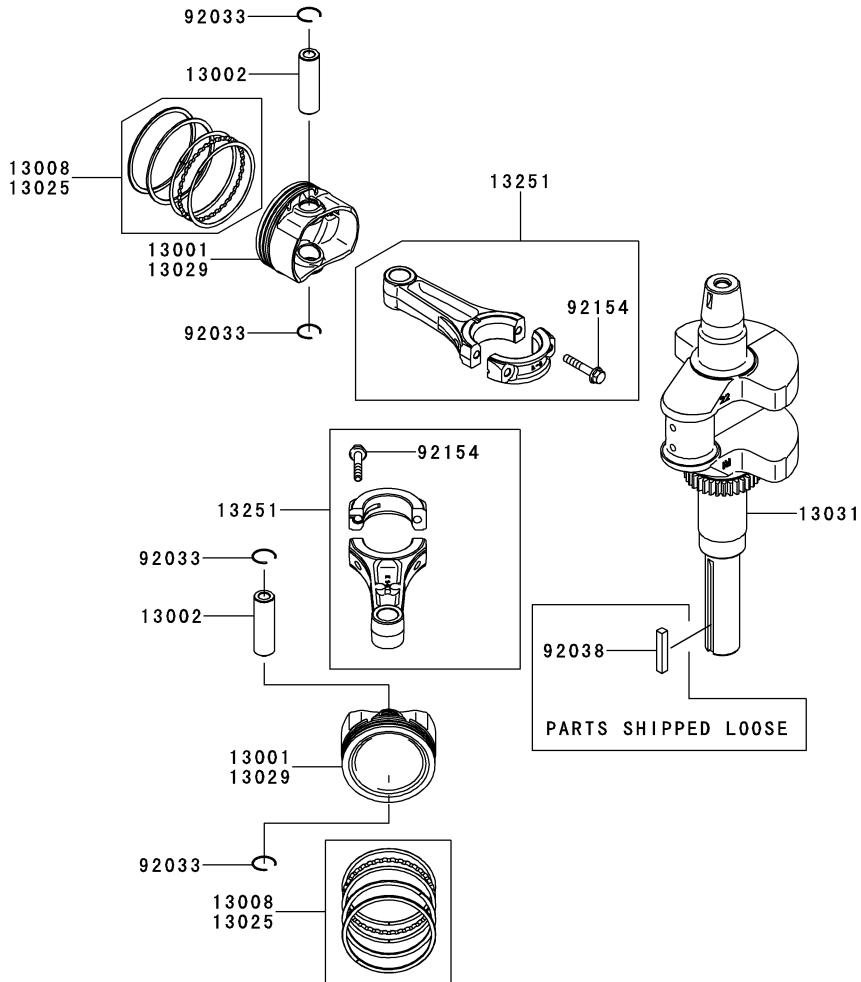

Ref. No.	Part No.	Description	Quantity
13001	13001-7027	PISTON-ENGINE	2
13002	13002-0704	PIN-PISTON	2
13008	13008-7005	RING-SET-PISTON	2
13025	13025-7009	RING-SET-PISTON L,0.5	AR
13029	13029-7010	PISTON-ENGINE L,0.5	AR
13031	13031-0824	CRANKSHAFT-COMP	1
13251	13251-0719	ROD-ASSY-CONNECTING	2
92033	92033-0755	RING-SNAP	4
92038	92038-2101	KEY	1
92154	92154-2842	BOLT,6X35	4

This catalog covers:  
**FS691V- AG80**

**03 VALVE/CAMSHAFT**

This fig. covers:

E0130-A248A

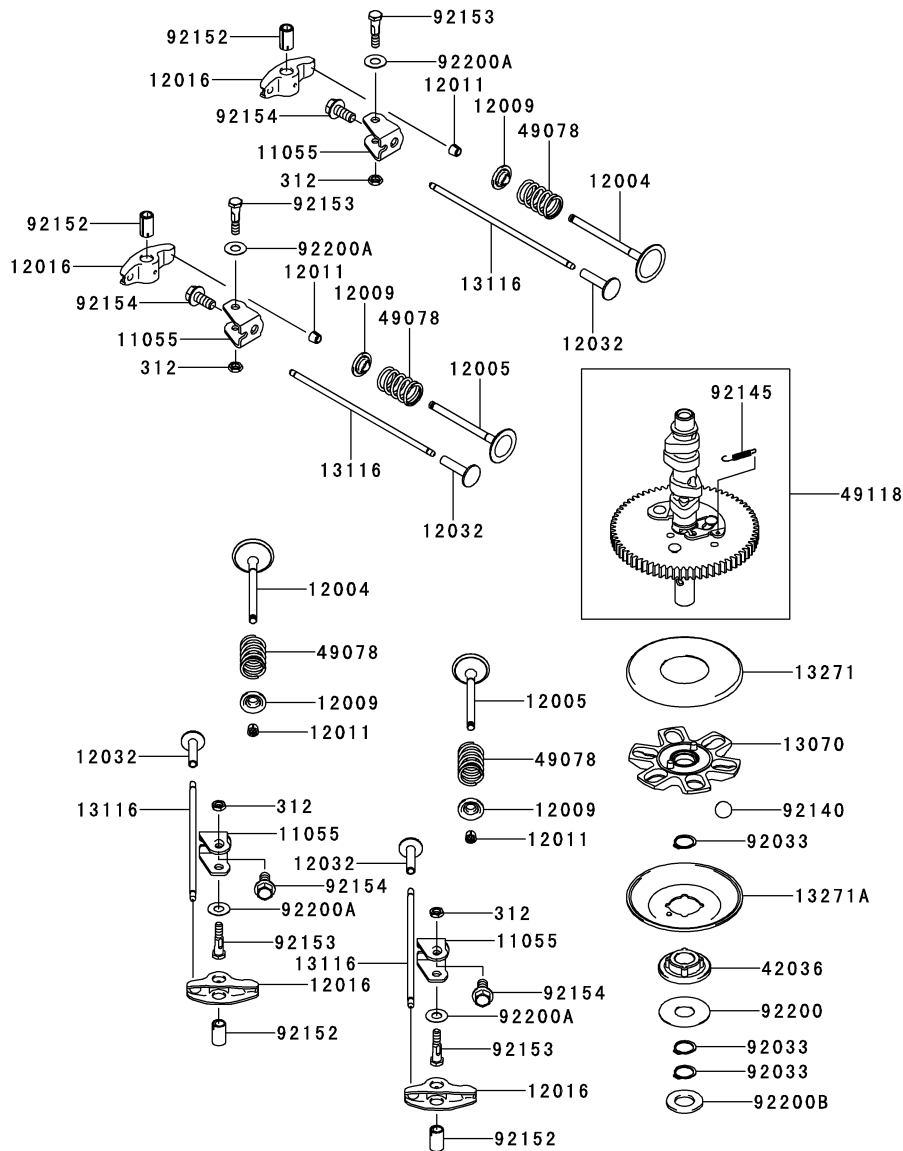

Ref. No.	Part No.	Description	Quantity
11055	11055-7009	BRACKET	4
12004	12004-0733	VALVE-INTAKE	2
12005	12005-0750	VALVE-EXHAUST	2
12009	12009-7001	RETAINER-VALVE SPRING	4
12011	12011-2056	COLLET	8
12016	12016-0040	ARM-ROCKER	4
12032	12032-7001	TAPPET	4
13070	13070-7017	GUIDE, GOVERNOR	1
13116	13116-0725	ROD-PUSH	4
13271	13271-7007	PLATE	1
13271A	13271-7021	PLATE, GOVERNOR	1
42036	42036-7021	SLEEVE	1
49078	49078-7002	SPRING-ENGINE VALVE, IN	4
49118	49118-7022	CAMSHAFT-COMP	1
92033	92033-0727	RING-SNAP	3
92140	92140-7005	BALL	6
92145	92145-1653	SPRING	1
92152	92152-1689	COLLAR	4
92153	92153-7100	BOLT, 6X29.5	4
92154	92154-1267	BOLT, 8X18.2	4
92200	92200-0945	WASHER, 16X42X0.91	1
92200A	92200-2151	WASHER, 8.1X18X0.5	4
92200B	92200-7048	WASHER, 16.3X30X2.28	1
312	312AA0600	NUT-HEX, 6MM	4

This catalog covers:  
**FS691V- AG80**

This fig. covers:  
**04 LUBRICATION-EQUIPMENT**

E0140-A506P

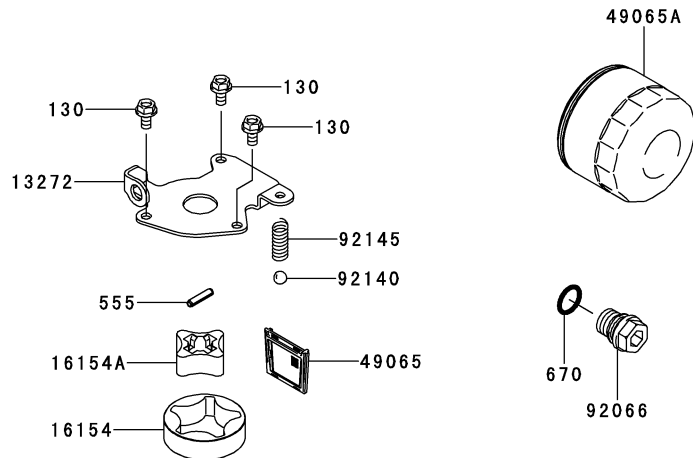
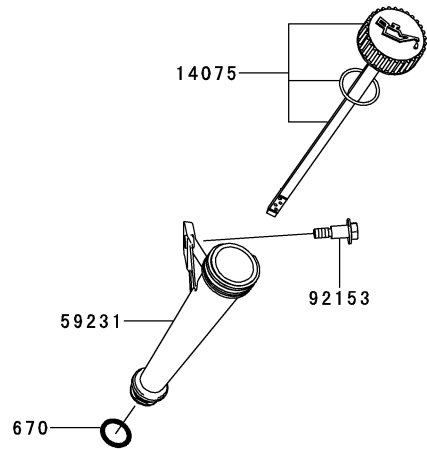

Ref. No.	Part No.	Description	A	Quantity
13272	13272-7011	PLATE,ROTOR	1	
14075	14075-0037	CAP-ASSY	1	
16154	16154-7010	ROTOR-PUMP,OUTER	1	
16154A	16154-7011	ROTOR-PUMP,INNER	1	
49065	49065-7006	FILTER-OIL	1	
49065A	49065-7007	FILTER-OIL	1	
59231	59231-0712	FILLER	1	
92066	92066-0774	PLUG	1	
92140	92140-7003	BALL,STEEL,13/32	1	
92145	92145-1658	SPRING	1	
92153	92153-7008	BOLT	1	
130	130BA0612	BOLT-FLANGED,6X12	3	
555	555A0420	PIN-SPRING,4X20	1	
670	670D2016	O RING,16MM	2	

This catalog covers:  
**FS691V- AG80**

This fig. covers:  
**05 COOLING-EQUIPMENT**

E0150-B347A

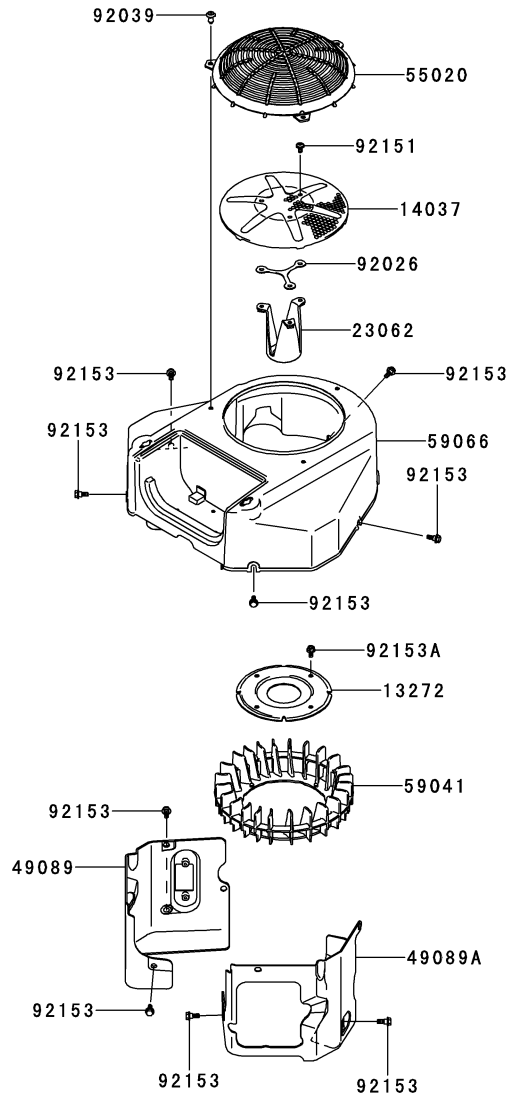

Ref. No.	Part No.	Description	Quantity
13272	13272-1487	PLATE,FAN	1
14037	14037-7008-9H	SCREEN	1
23062	23062-7024	BRACKET-COMP	1
49089	49089-7077	SHROUD-ENGINE	1
49089A	49089-7078	SHROUD-ENGINE	1
55020	55020-0900	GUARD	1
59041	59041-7014	FAN	1
59066	59066-0043	HOUSING-FAN	1
92026	92026-7007	SPACER	1
92039	92039-0751	RIVET, GUARD	3
92151	92151-7012	BOLT, 6X12	3
92153	92153-7007	BOLT, FLANGED, 6X16	9
92153A	92153-7043	BOLT, 6X12	4

This catalog covers:  
**FS691V- AG80**

This fig. covers:  
**06 ELECTRIC-EQUIPMENT**

E0160-B841A

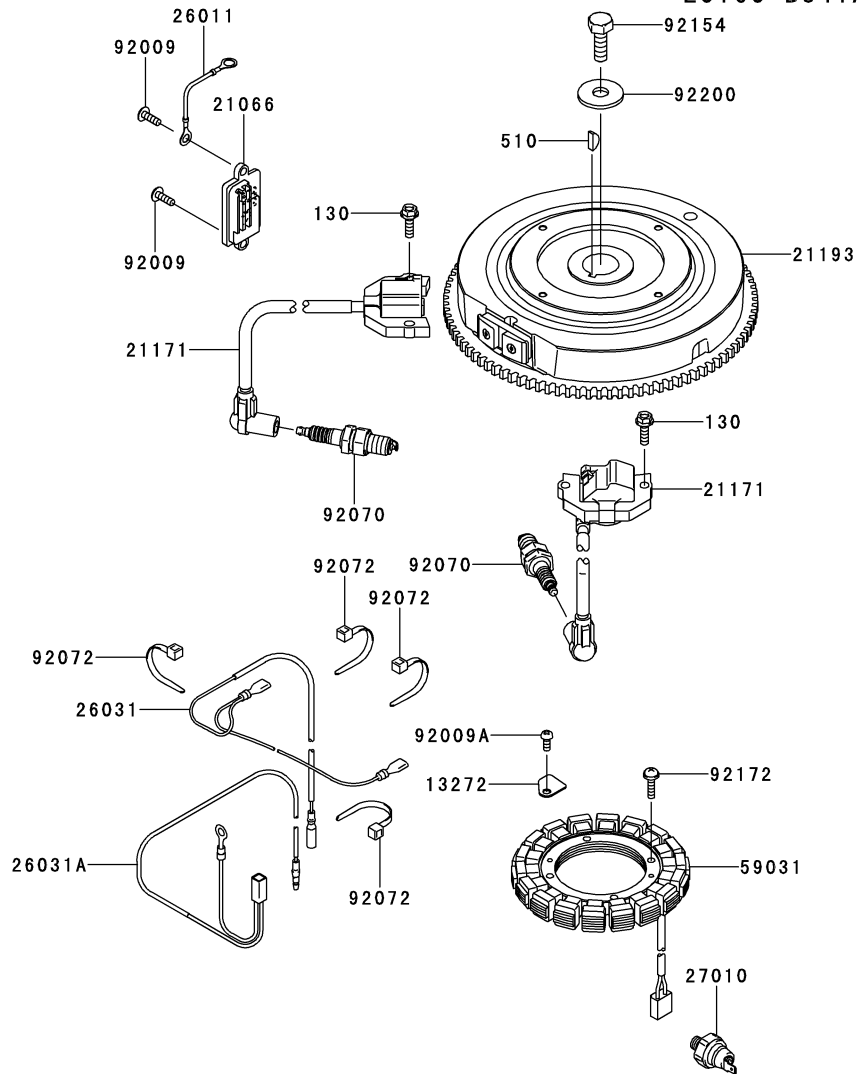

Ref. No.	Part No.	Description	Quantity
13272	13272-7012	PLATE	1
21066	21066-7017	REGULATOR-VOLTAGE	1
21171	21171-0740	COIL-ASSY-IGNITION	2
21193	21193-0036	FLYWHEEL-ASSY	1
26011	26011-2234	WIRE-LEAD	1
26031	26031-7040	HARNESS	1
26031A	26031-7041	HARNESS	1
27010	27010-0818	SWITCH	1
59031	59031-7017	COIL-CHARGING	1
92009	92009-2303	SCREW	2
92009A	92009-2308	SCREW	1
92070	92070-7004	PLUG-SPARK,BPR4ES(NGK),SOLID	2
92072	92072-7003	BAND	4
92154	92154-7003	BOLT,12X30	1
92172	92172-7018	SCREW,5X20	4
92200	92200-7002	WASHER	1
130	130BA0620	BOLT-FLANGED,6X20	4
510	510A5100	KEY-WOODRUFF	1



This catalog covers:  
**FS691V- AG80**

This fig. covers:  
**07 CONTROL-EQUIPMENT**

E0170-A753B

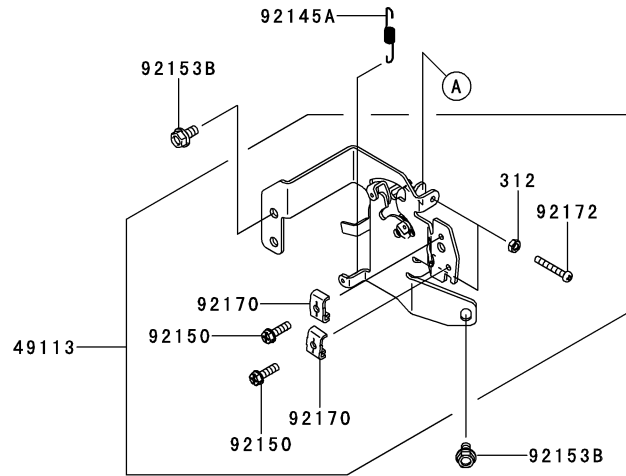

Ref. No.	Part No.	Description	Quantity
13107	13107-7047	SHAFT,GOVERNOR	1
13271	13271-7038	PLATE	1
16171	16171-0033	LINK	1
39129	39129-7035	SPRING-GOVERNOR	1
49103	49103-7014	ARM-GOVERNOR	1
49103A	49103-7015	ARM-GOVERNOR	1
49113	49113-0727	PANEL-COMP-CONTROL	1
92145	92145-7057	SPRING	1
92145A	92145-7058	SPRING	1
92150	92150-2182	BOLT,5X18	2
92153	92153-0009	BOLT,6X12	1
92153A	92153-7033	BOLT,6X35	1
92153B	92153-7043	BOLT,6X12	2
92170	92170-7001	CLAMP	2
92172	92172-0792	SCREW,5X35	2
92172A	92172-0870	SCREW,4X8	2
311	311AA0600	NUT-HEX,6MM	1
312	312AA0500	NUT-HEX,5MM	2
411	411AA0600	WASHER-PLAIN,6MM	1

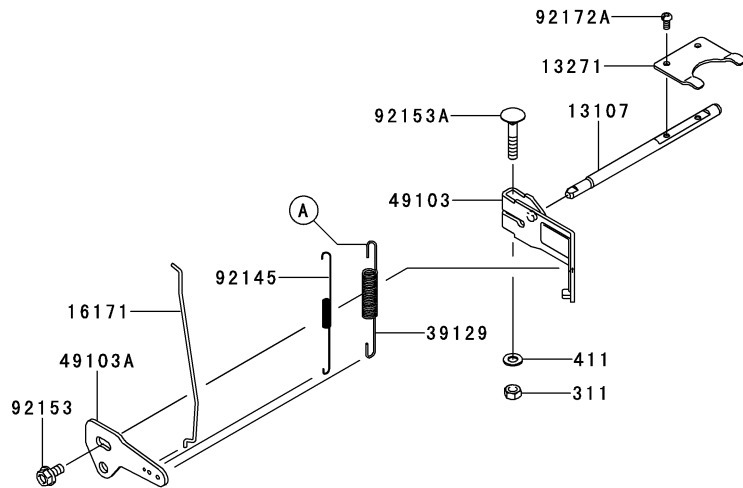

This catalog covers:  
**FS691V- AG80**

This fig. covers:  
**08 CARBURETOR**

E0180-B140B

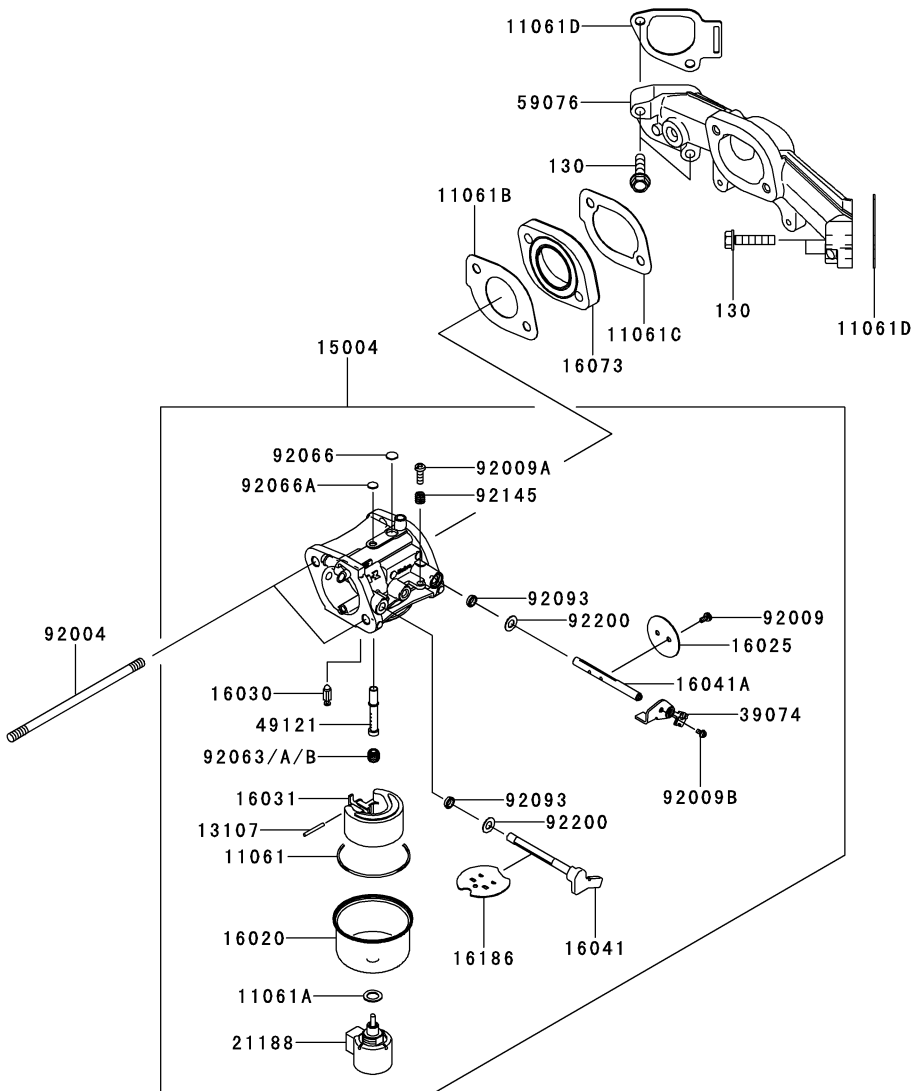

Ref. No.	Part No.	Description	Quantity
11061	11061-7009	GASKET,CHAMBER	1
11061A	11061-7010	GASKET,SCREW	1
11061B	11061-7087	GASKET,INSULATOR	1
11061C	11061-7088	GASKET,INSULATOR/MANIFOLD	1
11061D	11061-7093	GASKET,MANIFOLD	2
13107	13107-7018	SHAFT	1
15004	15004-0985	CARBURETOR-ASSY	1
16020	16020-7003	CHAMBER-FLOAT	1
16025	16025-7017	VALVE-THROTTLE	1
16030	16030-7003	VALVE-FLOAT	1
16031	16031-7002	FLOAT	1
16041	16041-0007	SHAFT-CARBURETOR,CHOKE	1
16041A	16041-7051	SHAFT-CARBURETOR,THROTTLE	1
16073	16073-7013	INSULATOR	1
16186	16186-7006	VALVE-ASSY-CHOKE	1
21188	21188-7002	SOLENOID	1
39074	39074-7001	LEVER-ASSY-THROTTLE	1
49121	49121-7018	NOZZLE-MAIN	1
59076	59076-0009	MANIFOLD-INTAKE	1
92004	92004-0723	BOLT-STUD,6X115	2
92009	92009-2083	SCREW	2
92009A	92009-2349	SCREW	1
92009B	92009-2402	SCREW	1
92063	92063-7141	JET-MAIN,#122,3280FT	1
92063A	92063-7142	JET-MAIN,#124	1
92063B	92063-7149	JET-MAIN,#120,6560FT	1
92066	92066-2204	PLUG	1
92066A	92066-2244	PLUG	1
92093	92093-0593	SEAL	2
92145	92145-1579	SPRING	1
92200	92200-0848	WASHER	2
130	130AA0630	BOLT-FLANGED,6X30	4

This catalog covers:  
**FS691V- AG80**

**09 AIR-FILTER/MUFFLER**

This fig. covers:

E0190-B688A

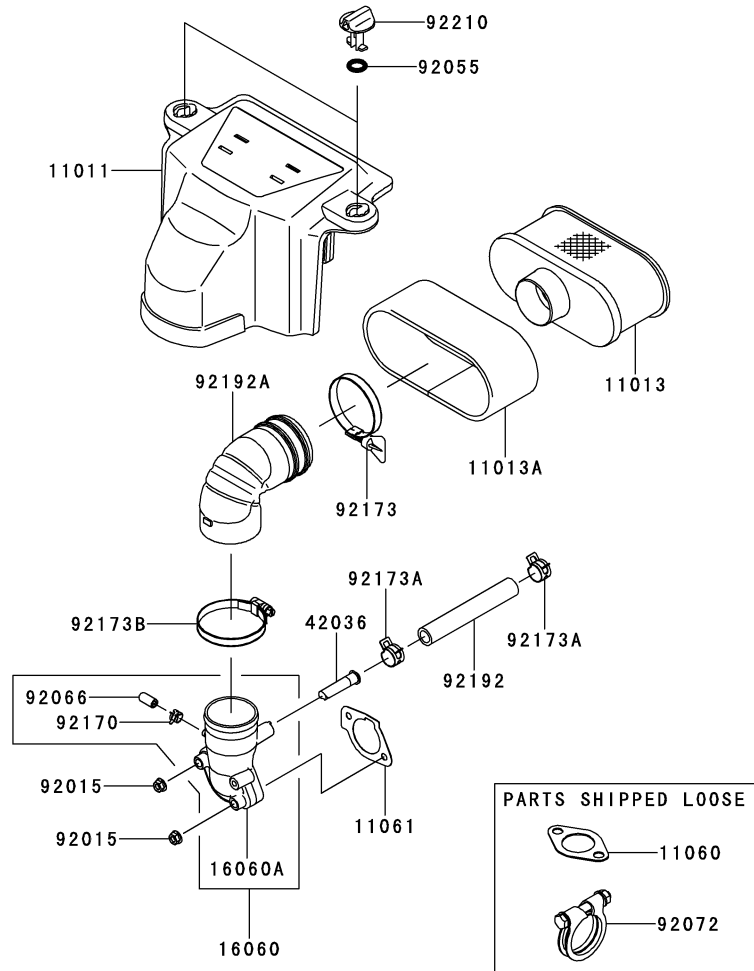

Ref. No.	Part No.	Description	Quantity
11011	11011-0786	CASE-AIR FILTER	1
11013	11013-0752	ELEMENT-AIR FILTER	1
11013A	11013-7046	ELEMENT-AIR FILTER	1
11060	11060-7016	GASKET,MUFFLER	2
11061	11061-7086	GASKET,CARBURETOR/PIPE-INTAKE	1
16060	16060-0048	PIPE-INTAKE	1
16060A	16060-7038	PIPE-INTAKE	1
42036	42036-7022	SLEEVE,BREATHER	1
92015	92015-1367	NUT,FLANGED,6MM	2
92055	92055-7025	RING-O	2
92066	92066-0095	PLUG	1
92072	92072-7013	BAND	1
92170	92170-2042	CLAMP	1
92173	92173-1001	CLAMP	1
92173A	92173-7003	CLAMP	2
92173B	92173-7010	CLAMP	1
92192	92192-7146	TUBE,12.6X18.6X118	1
92192A	92192-7165	TUBE	1
92210	92210-7038	NUT	2

This catalog covers:  
**FS691V- AG80**

**10**

This fig. covers:  
**FUEL-TANK/FUEL-VALVE**

E0200-A880D

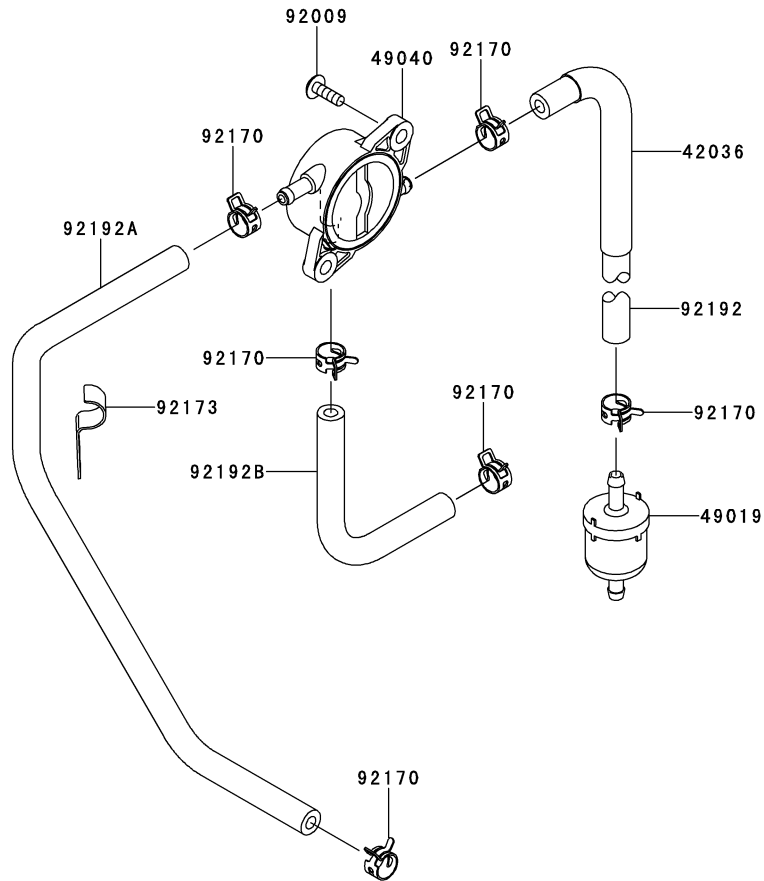

Ref. No.	Part No.	Description	Quantity
42036	42036-7015	SLEEVE	1
49019	49019-0027	FILTER-FUEL	1
49040	49040-7008	PUMP-FUEL	1
92009	92009-2303	SCREW	2
92170	92170-2009	CLAMP	6
92173	92173-1000	CLAMP	1
92192	92192-1551	TUBE,6.35X12.7X185	1
92192A	92192-1555	TUBE,6.35X12.7X390	1
92192B	92192-7148	TUBE,6.4X12.7X150	1

This catalog covers:  
**FS691V- AG80**

**11 STARTER**

This fig. covers:

E0210-A726A

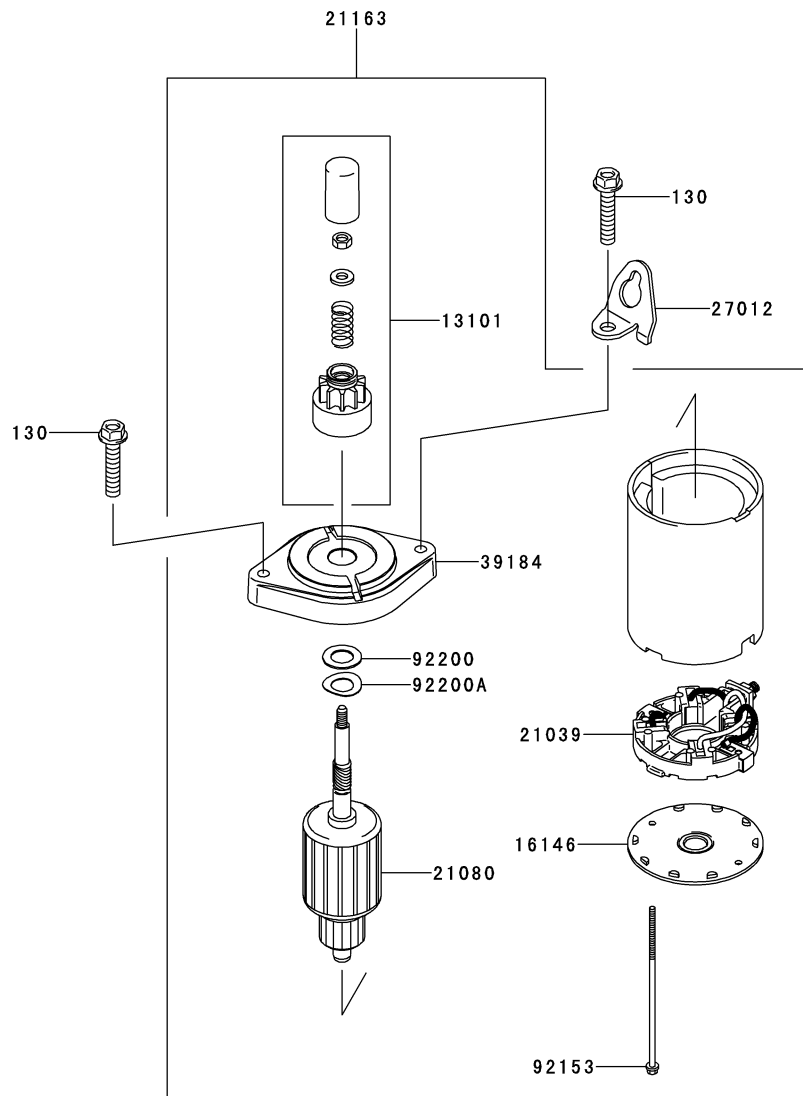

Ref. No.	Part No.	Description	Quantity
13101	13101-0650	GEAR-ASSY	1
16146	16146-7013	COVER-ASSY	1
21039	21039-7002	BRUSH	1
21080	21080-0009	ARMATURE	1
21163	21163-0749	STARTER-ELECTRIC	1
27012	27012-7008	HOOK	1
39184	39184-0019	BRACKET-ASSY	1
92153	92153-7034	BOLT	2
92200	92200-7023	WASHER	1
92200A	92200-7024	WASHER	1
130	130BA0840	BOLT-FLANGED,8X40	2

This catalog covers:  
**FS691V- AG80**

**12**

This fig. covers:  
**LABEL**

F0290-B859A

Ref. No.	Part No.	Description	Quantity
56033	56033-7001	LABEL-MANUAL	1
56071	56071-0366	LABEL-WARNING	1
56080	56080-0746	LABEL-BRAND	1

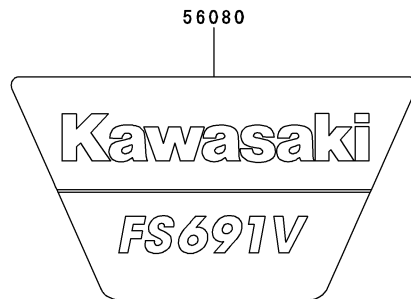
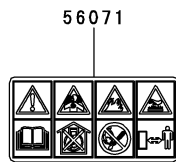
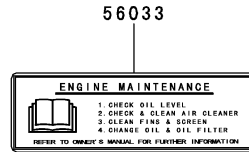

*This catalog covers:*

**FS691V- AG80**

*This fig. covers:*

---

## PART NAME INDEX

AIR-FILTER/MUFFLER .....	09
CARBURETOR .....	08
CONTROL-EQUIPMENT .....	07
COOLING-EQUIPMENT .....	05
CYLINDER/CRANKCASE .....	01
ELECTRIC-EQUIPMENT .....	06
FUEL-TANK/FUEL-VALVE .....	10
LABEL .....	12
LUBRICATION-EQUIPMENT .....	04
PISTON/CRANKSHAFT .....	02
STARTER .....	11
VALVE/CAMSHAFT .....	03

This catalog covers:

## FS691V- AG80

This fig. covers:

## NUMERICAL PARTS INDEX

Part No.	Fig No.	Part No.	Fig No.	Part No.	Fig No.	Part No.	Fig No.	Part No.	Fig No.
11004-7026	01	16060-0048	09	670B2011	01	92170-2009	10		
11008-0845	01	16060-7038	09	670D2016	04	92170-2042	09		
11008-0861	01	16073-7013	08	92004-0723	08	92170-7001	07		
11011-0786	09	16126-7020	01	92009-2083	08	92172-0792	07		
11013-0752	09	16146-7013	11	92009-2303	06	92172-0870	01		
11013-7046	09	16154-7010	04	92009-2303	10	92172-0870	07		
11022-0038	01	16154-7011	04	92009-2308	06	92172-7018	06		
11022-0710	01	16171-0033	07	92009-2349	08	92173-1000	10		
11055-7009	03	16186-7006	08	92009-2402	08	92173-1001	09		
11060-7016	09	172BA0822	01	92015-1367	09	92173-7003	09		
11061-7009	08	21039-7002	11	92026-7007	05	92173-7010	09		
11061-7010	08	21066-7017	06	92033-0727	03	92192-1551	10		
11061-7083	01	21080-0009	11	92033-0755	02	92192-1555	10		
11061-7086	09	21163-0749	11	92038-2101	02	92192-7146	09		
11061-7087	08	21171-0740	06	92039-0751	05	92192-7148	10		
11061-7088	08	21188-7002	08	92043-0858	01	92192-7165	09		
11061-7093	08	21193-0036	06	92043-1263	01	92200-0848	08		
11061-7094	01	23062-7024	05	92049-7001	01	92200-0945	03		
12004-0733	03	26011-2234	06	92049-7010	01	92200-2151	03		
12005-0750	03	26031-7040	06	92049-7019	01	92200-7002	06		
12009-7001	03	26031-7041	06	92049-7028	01	92200-7023	11		
12011-2056	03	27010-0818	06	92055-7025	09	92200-7024	11		
12016-0040	03	27012-7008	11	92063-7141	08	92200-7048	03		
12032-7001	03	311AA0600	07	92063-7142	08	92210-7038	09		
13001-7027	02	312AA0500	07	92063-7149	08				
13002-0704	02	312AA0600	03	92066-0095	09				
13008-7005	02	32155-7003	01	92066-0761	01				
13025-7009	02	39074-7001	08	92066-0762	01				
13029-7010	02	39129-7035	07	92066-0774	04				
13031-0824	02	39184-0019	11	92066-2204	08				
13070-7017	03	411AA0600	07	92066-2223	01				
130AA0630	08	42036-7015	10	92066-2244	08				
130BA0612	04	42036-7021	03	92070-7004	06				
130BA0620	06	42036-7022	09	92072-7003	06				
130BA0625	01	49015-0023	01	92072-7013	09				
130BA0840	11	49019-0027	10	92093-0593	08				
130CA1050	01	49040-7008	10	92104-0007	01				
130CA1065	01	49065-7006	04	92140-7003	04				
13101-0650	11	49065-7007	04	92140-7005	03				
13107-7018	08	49078-7002	03	92145-1579	08				
13107-7047	07	49089-7077	05	92145-1653	03				
13116-0725	03	49089-7078	05	92145-1658	04				
13251-0719	02	49103-7014	07	92145-7057	07				
13271-7007	03	49103-7015	07	92145-7058	07				
13271-7021	03	49113-0727	07	92150-2182	07				
13271-7038	07	49118-7022	03	92151-7012	05				
13272-1374	01	49120-0858	01	92152-1689	03				
13272-1487	05	49121-7018	08	92153-0009	07				
13272-7011	04	510A5100	06	92153-7007	05				
13272-7012	06	55020-0900	05	92153-7008	04				
14037-7008-9H	05	555A0420	04	92153-7033	07				
14075-0037	04	56033-7001	12	92153-7034	11				
14093-0455	01	56071-0366	12	92153-7043	01				
15004-0985	08	56080-0746	12	92153-7043	05				
16020-7003	08	59031-7017	06	92153-7043	07				
16025-7017	08	59041-7014	05	92153-7054	01				
16030-7003	08	59066-0043	05	92153-7100	03				
16031-7002	08	59071-0733	01	92154-1267	03				
16041-0007	08	59076-0009	08	92154-2842	02				
16041-7051	08	59231-0712	04	92154-7003	06				