

GENERAL PURPOSE ENGINE

GXV340UT2
GXV340RT2

PARTS CATALOGUE

2

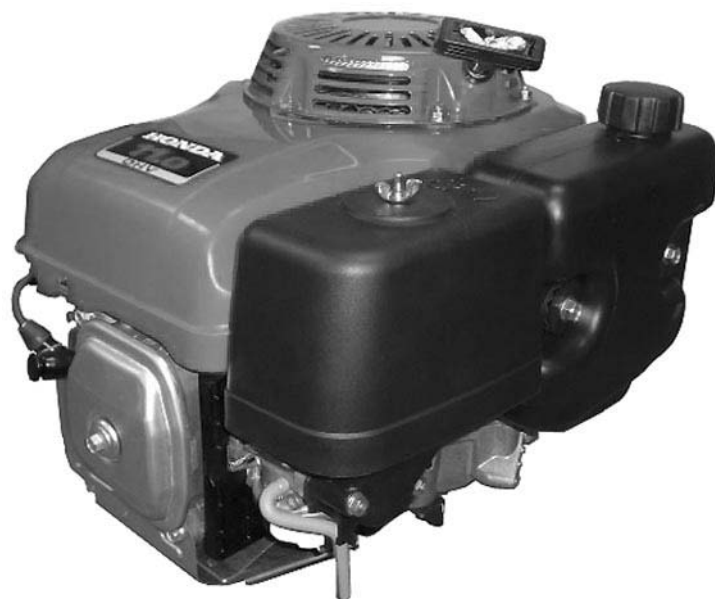

GXV340UT2

FOREWORD INDEX

1

ENGINE GROUP

2

PART NUMBER INDEX

3

PART NAME INDEX

4

Instruction for use of parts catalogue

- **This parts catalogue was prepared based on the latest information available as of February 10, 2008.**
- See the parts catalogue news for any revision that is made after February 10, 2008.
- **Always specify the part number when ordering a part.**
 - Check the model, type, serial numbers, color, maker, and the size as needed before ordering a part.
 - Note that the illustrations (part drawings) can differ from the actual parts in shape. They are given just to help you to refer to the parts.
- **When modifications or additions to this parts catalogue are made, a revised edition will be issued at an appropriate time, with successively progressing revision numbers on the cover. We recommend obtaining such revisions in order to keep your parts catalogue up-to-date at all times. To check whether a parts catalogue revision has been issued, please contact your Honda distributor.**

Initial version issue date **June 10, 2005**
Honda Motor Co., Ltd.

CONTENTS

	Page	Address No.	
● Instruction for use of parts catalogue	1	B 1	1
● How to refer to the part information	2	B 2	
● Part catalogue structure	3	B 3	
● When the parts were revised	4	B 4	
● Abbreviations used in the parts catalogue	4	B 4	
● How to check the part block and serial numbers	5	B 5	
● Models, parts catalogue codes and applicable serial numbers	6	B 6	
● Features of each type	7	B 7	
● Fuel hose, general purpose hoses and vinyl hose	8	B 8	
● FLAT RATE SERVICE TIME	9	B 9	
● Illustrated index	14	B14	
● ENGINE GROUP	17	C 1	2
● PART NO. INDEX	47	E 1	3
● PART NAME INDEX	49	F 1	4

How to refer to the part information

A Reference with "Illustrated index"

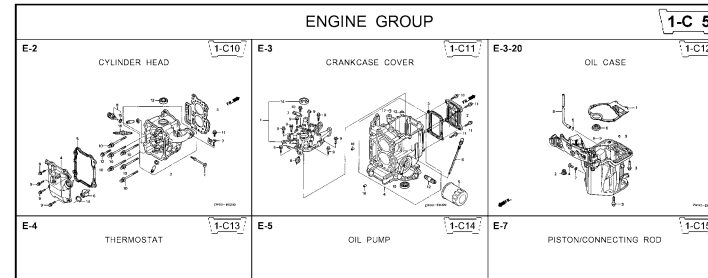

B Reference with "Part number index"

PART NO. INDEX

Part Number	Address	Page	Ref.	Part Number	Address	Page
06000				15212-ZW9-000	1-C14	3C
06316-ZW9-000	1-G9	88	1	15220-ZW9-003	1-C14	3C
11000				15332-ZW9-000	1-E8	55
11300-ZW9-405	1-C11	27	1	15332-ZW9-A30	1-E11	5E
11300-ZW9-406	1-C11	27	1	15400-PF8-004	1-C11	27
11340-ZW9-000	1-C11	27	2	15422-ZW9-000	1-C14	3C
11342-ZW9-000	1-C11	27	3	15473-881-000	1-C14	3C
11381-ZW9-003	1-C12	28	1	15474-ZW9-000	1-C14	3C
				15611-921-000	1-C10	2E
				15655-ZW9-000	1-C11	27
				16000		
12000				16010-ZV4-005	1-D4	3E
12000-ZW9-405ZA	1-C11	27	4	16011-ZV4-005	1-D4	3E
12155-ZV4-A00	1-C13	29	1	16013-ZW9-003	1-D4	3E
12166-ZW9-000	1-C10	26	1	16016-ZW9-003	1-D4	3E
12209-GB4-681	1-C16	32	1	16016-ZW9-721	1-D4	3E
12210-ZW9-405ZA	1-C10	26	2	16023-ZW9-003	1-D4	3E
12216-ZE2-300	1-E8	55	1	16024-ZV4-650	1-D4	3E
	1-E11	58	1	16028-ZV4-650	1-D4	3E

C Reference with "Part name index"

PART NAME INDEX

Part name	Address	Page	Ref.
[A]			
ABSORBER , FUEL	1-E15	62	5
ARMATURE COMP.	1-D11	43	7
ARM COMP. , LINK JOINT	1-G6	85	18
ARM COMP. , SHIFT LINK	1-G6	85	14
ARM COMP. , TILT	1-F15	79	20
ARM , FUEL PUMP ROCKER	1-C16	32	4
ARM , REVERSE LOCK	1-F15	79	18
ARM , SHIFT LINK	1-F11	74	7
ARM , STOPPER	1-D1	33	12
ARM , THROTTLE REMOTE	1-F11	74	6
ARM , VALVE ROCKER	1-C16	32	3
[B]			
BAG , TOOL , 160MM	1-G5	84	10
BAND	1-G6	86	37
BAND B1 , WIRE	1-F6	69	1
BAND , CORD	1-F3	67	18
BAND , TUBE CLIP , 11MM	1-E15	63	20
BAND , TUBE CLIP , 12.5MM	1-E15	63	19

Address No. 1-C10

E-2 CYLINDER HEAD

Block No.

Ref No.

Ref. No.	Part No.	Description	Reqd. QTY						Serial No.	Parts catalogue code
			99D1	99D1	10D1	10D1	10B1	10B1		
1	12166-ZW9-000	STOPPER, ENGINE SIDE	2	2	2	2	2	2		
2	12210-ZW9-000ZA	HEAD COMP., CYLINDER	1	1	1	1	1	1		
3	12251-ZW9-003	GASKET, CYLINDER HEAD	1	1	1	1	1	1		
4	12310-ZW9-000	COVER COMP., HEAD	1	1	1	1	1	1		
5	12312-ZW9-000	PACKING, HEAD COVER	1	1	1	1	1	1		
6	15611-921-000	CAP, OIL	1	1	1	1	1	1		
7	16617-ZW9-000	HOLDER, CABLE	1	1	1	1	1	1	SC,SG	
	16617-ZW9-010		1	1	1	1	1	1	1001800	LHC,LHD
			1	1	1	1	1	1	1001801	LHC,LHD
8	35675-ZW5-003	SENSOR ASSY., WATER	1	1	1	1	1	1		
9	90003-ZW9-000	BOLT, FLANGE, 6X22	1	4	4	4	4	4		
10	90007-ZW9-003	BOLT, FLANGE, 8X83	6	6	6	6	6	6		
11	90011-ZW9-000	BOLT, FLANGE, 6X14(CT200)	1	1	1	1	1	1		
12	90020-ZW9-000	BOLT, FLANGE, 8X40	2	2	2	2	2	2		
13	91202-KJ9-003	OIL SEAL, 20X32X6	1	1	1	1	1	1		
14	91301-805-000	O-RING, 26X2.7	1	1	1	1	1	1		
15	91307-PK2-005	O-RING, 9.5X1.5(HONDA KIKAKI)	1	1	1	1	1	1		
16	98059-55916	PLUG, SPARK (CR5EH-9)	2	2	2	2	2	2		
	98059-55926	PLUG, SPARK (U16FER9)	2	2	2	2	2	2		

Service item F.R.T.

- O-RING, 26X2.7 0.1
- PLUG, SPARK 0.2
- O-RING, 9.5X1.5 0.2
- SENSOR ASSY., WATER TEMPERATURE 0.3
- COVER COMP., HEAD 0.3
- PACKING, HEAD COVER 1.8
- GASKET, CYLINDER HEAD 2.4
- OIL SEAL, 20X32X6 2.4
- HEAD COMP., CYLINDER 3.1

2008.09.20 E

Page No.

Part catalogue structure

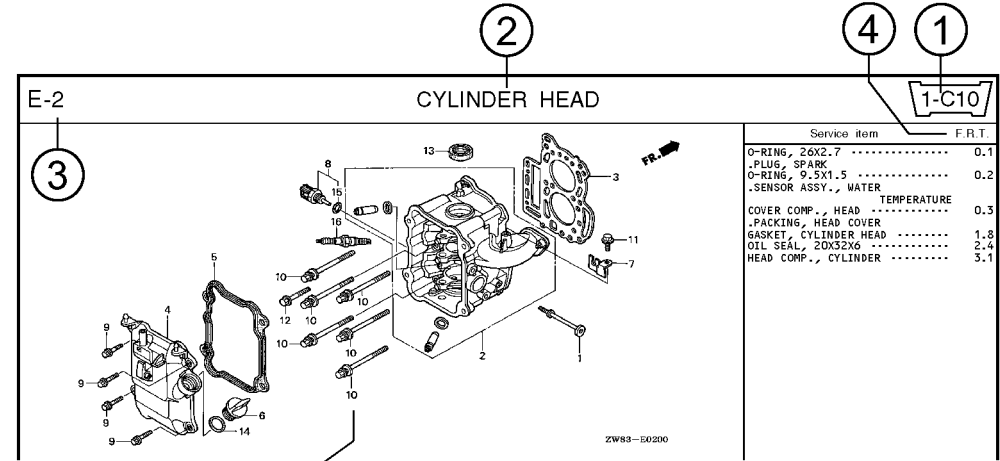

Ref. No.	Part No.	Description	Reqd. QTY						Serial No.	Parts catalogue code
			BF 9/9D1	BFP 9/9D1	BF 10D1	BFP 10D1	BF 10B1	BFP 10B1		
1	12166-ZW9-000	STOPPER, ENGINE SIDE	2	2	2	2	2	2		
2	12210-ZW9-000ZA	HEAD COMP., CYLINDER *NHS* DARK GRAY	1	1	1	1	1	1		
3	12251-ZW9-003	GASKET, CYLINDER HEAD	1	1	1	1	1	1		
4	12310-ZW9-000	COVER COMP., HEAD	1	1	1	1	1	1		
5	12312-ZW9-000	PACKING, HEAD COVER	1	1	1	1	1	1		
6	15611-921-000	CAP, OIL (NO GAUGE)	1	1	1	1	1	1		
7	16617-ZW9-000	HOLDER, CABLE	1	1	1	1	1	1	SC,SG	
	16617-ZW9-010		1	1	1	1	1	1	1001800 LHC,LHD	

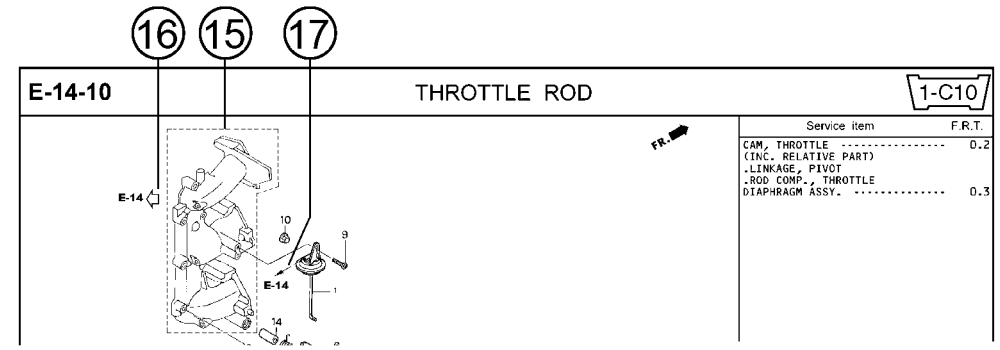

- ① **Address number**
 - Address No. is provided (in place of the page No.) to help you refer to the part with the part No. or part name.
- ② **Block title** ③ **Block number**
- ④ **Service item/Flat rate time**
- ⑤ **Reference number**
 - Title number marked with the parenthesis or parentheses indicates that it continues from the previous page.
- ⑥ **Part number** ⑦ **Honda color code**
- ⑧ **Description**
- ⑨ **Assemblies**
 - Sections framed with broken lines in the exploded view drawings are available as complete assemblies. (Their individual parts can also be obtained.)
- ⑩ **Color description**
- ⑪ **Note**
 - Notes are shown with the parentheses in the part name column.
- ⑫ **Required quantity**
 - Required QTY shown in the parenthesis or parentheses indicates the optional part.
 - Required QTY marked with "N" Indicates the optional part that should be selected as needed.
 - Required QTY indicates the number of the part used in the block.
- ⑬ **Serial number**
- ⑭ **Type**
 - When the type column is blank, it indicates that the part is applicable to all types.
 - As the type of the actual unit may differ from the "parts catalogue, type" please refer to "Models, types and applicable serial numbers" for confirmation.
- ⑮ **[Dotted line box]**
 - Parts enclosed within a dotted line [] are covered in a different block.
- ⑯ **[Hollow arrow]**
 - A hollow arrow ↖ indicates the block No. for the parts enclosed within a dotted line [] .
- ⑰ **[Solid arrow]**
 - A solid arrow ← indicates the block No. the part in question is connected to.

When the parts were revised

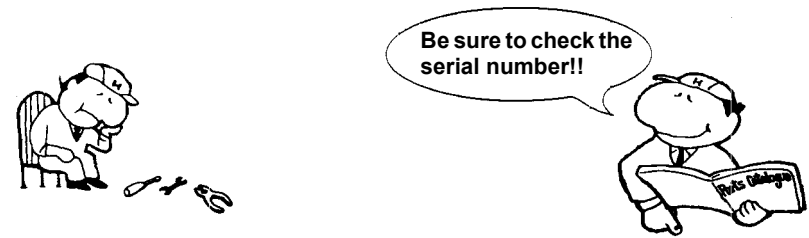

Ref. No.	Part No.	Description	Reqd. QTY						Serial No.
			BF 99D1	BFP 9.9D1	BF 10D1	BFP 10D1	BF 10B1	BFP 10B1	
1	12166-ZW9-000	STOPPER, ENGINE SIDE	2	2	2	2	2	2	
2	12210-ZW9-000ZA	HEAD COMP., CYLINDER *NHS* DARK GRAY	1	1	1	1	1	1	
3	12251-ZW9-003	GASKET, CYLINDER HEAD	1	1	1	1	1	1	
4	12310-ZW9-000	COVER COMP., HEAD	1	1	1	1	1	1	
5	12312-ZW9-000	PACKING, HEAD COVER	1	1	1	1	1	1	
6	15611-921-000	CAP, OIL (NO GAUGE)	1	1	1	1	1	1	
7	16617-ZW9-000	HOLDER, CABLE (###)	1	1	1	1	1	1	SC, SG LHC, LHD LHC, LHD
	16617-ZW9-010	1	1	1	1	1	1	

The number has been used from the initial model without revision.

When shown at the left side, it is applicable to the models of No.1001801 and the subsequent numbers.

When shown at the right side, it is applicable to the models up to No.1001800.

• The parts listed with "###" at the end of the parts name have limited supply period (parts not for sale).

Abbreviations used in the parts catalogue

• The following abbreviations are used in the parts name column.

- A Ampere
- A.C. Alternating current
- ASSY. Assembly
- AT. Automatic transmission
- C.D.I. Capacitive discharge ignition
- COMP. ... Complete
- D.C. Direct current
- EX. Exhaust
- G.F.C.I ... Ground fault circuit interruptor
- HEX. Hexagonal
- H.S.T. Hydrostatic transmission
- FR.Front
- IN.Inlet
- L (100L) .Link (100 Links)
- L.Left
- MMMillimeter
- MT.Manual Transmission
- P.T.O.Power take off
- R.Right
- RR.Rear
- STD.Standard
- T (22T) ...Tooth (22 Teeth)
- VVolt
- WWatt

How to check the part block and serial numbers

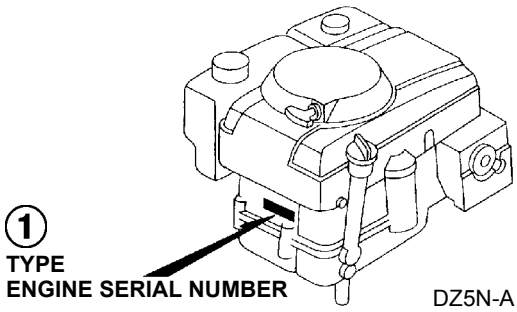
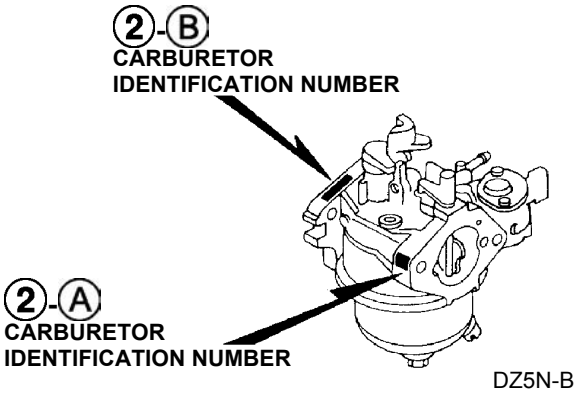
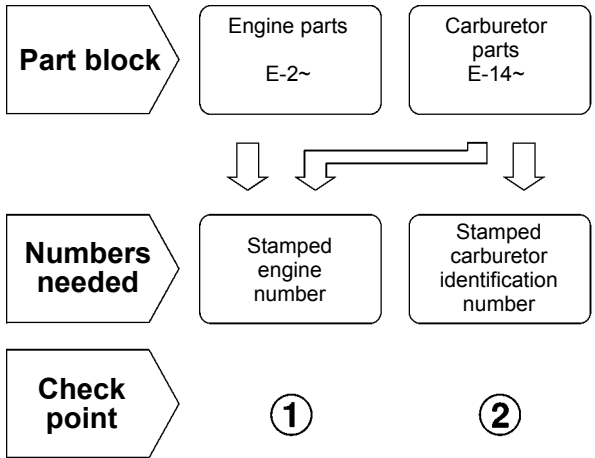

Models, parts catalogue codes and applicable serial numbers

- Models, parts catalogue codes and applicable serial Nos. given in this parts catalogue can be identified as follows.

Model	Type	Parts catalogue type	Applicable engine serial No.	Applicable carburetor identification No.	
GXV340UT2	DA	DA	GJACT-1000001~	BE81H A	
	DAS	DAS			
	DA2	DA2			
	DA23	DA23			
	DA33	DA33			
	DCAG	DCAG			
	DCA1	DCA1			
	DET3	DET3			
	DE33	DE33			
	DM33	DM33			
	DNE4	DNE4		BE81B C	
	DNG4	DNG4			
	DN4	DN4		BE81H A	
	DXE2	DXE2			
DX2	DX2				
DX3	DX3				
GXV340RT2	DA	DA			BE81H A
	DAS	DAS			
	DA2	DA2			
	DA23	DA23			
	DA33	DA33			
	DCAG	DCAG			
	DCA1	DCA1			
	DM33	DM33	BE81B C		

* Of carburetor identification numbers, only the portions underlined in the example below are used for registration.

BE 81H A KC ナ
 (A) (B)

Features of each type

- See the following table for the features of each type. (Items in brackets are optional)

Model Type	GXV340UT2															
	DA	DAS	DA2	DA23	DA33	DCAG	DCA1	DET3	DE33	DM33	DNE4	DNG4	DN4	DXE2	DX2	DX3
Oil filter cartridge		●		●				●								
Oil level switch			●	●	●	●								●	●	
Recoil starter	●	●	●	●	●			●	●		●	●	●	●	●	●
Spark arrester														●	●	●
Fuel tank								●	●		●	●	●	●	●	●
Charge coil		●				●	●	●	●	●	●			●		
Starter motor		●				●	●	●	●	●	●			●		
Engine stop switch	●		●	●	●			●	●		●	●	●	●	●	●
Buzzer			●	●	●									●	●	

Model Type	GXV340RT2							
	DA	DAS	DA2	DA23	DA33	DCAG	DCA1	DM33
Oil filter cartridge		●		●				
Oil level switch			●	●	●	●		
Recoil starter	●	●	●	●	●			
Spark arrester								
Fuel tank								
Charge coil		●				●	●	●
Starter motor		●				●	●	●
Engine stop switch	●		●	●	●			
Buzzer			●	●	●			

Fuel hose, general purpose hoses and vinyl hose

- The standard part fuel hose, general purpose hose and vinyl hose may be substituted by the coiled bulk part.
- When ordering the standard part fuel hose, general purpose hose and vinyl hose use the bulk part number written in the parts catalog in brackets () underneath the part name.
- When exchanging the hose, cut and use at the specified length as mentioned in the part name.
(For the method of cutting the bulk part, and method of filling out orders etc., please refer to the instructions issued with the bulk part.)

Bulk part number of fuel hose, general purpose hose and vinyl hose.

Example: 9 5 0 0 1 - 7 5 0 0 1 - 5 0 M

Bulk part number:
Refers to the bulk part.

Marking code (fuel hose and general purpose hose)

Change code (Vinyl hose)

Indicates number mark or change sequence, however, the code for the bulk part must be strictly 0 (zero).

Types of code:

- Fuel hose
 - 2: Red outside braid (3 mm inside dia. only)
 - 5: Black inside braid
 - 3: Red (3 mm inside dia. only)
 - 4: Ash gray with red stripe (3 mm inside dia. only)
 - 6: Black

- General hose
 - 1: Ash gray
 - 2: Ash gray
 - 3: Black
 - 5: Black

- Vinyl hose
 - 1: Clear
 - 2: Black
 - 3: Light red
 - 6: Light red
 - 7: Pale black

Lengths:

- 001: 1 m (standard)
 - 003: 3 m
 - 008: 8 m
- Application or specification of some parts is not settled.

I.D code: (fuel hose and general purpose hose)

- | | | | | |
|------------|--------------------|--------------------|-----------------------------|-----------------------------|
| 30: 3.0 mm | 50: 5.0 mm | 70: 7.0 mm | 11: 11 mm | 12: 12 (outside dia. 17) mm |
| 35: 3.5 mm | 55: 5.3 mm, 5.5 mm | 75: 7.3 mm, 7.5 mm | 91: 12 (outside dia. 15) mm | 14: 14 mm |
| 45: 4.5 mm | 65: 6.5 mm | 80: 8.0 mm | 92: 12 (outside dia. 16) mm | 17: 17 mm |

ID./OD. code: (vinyl hose)

- | | | | | |
|-------------------------|--------------------------|---------------------------|---------------------------|---------------------------|
| 01: ID. 2.9, OD. 6.8 mm | 12: ID. 5.0, OD. 7.0 mm | 21: ID. 8.0, OD. 9.0 mm | 37: ID. 11.0, OD. 15.0 mm | 50: ID. 16.0, OD. 19.0 mm |
| 03: ID. 3.0, OD. 6.0 mm | 10: ID. 5.0, OD. 8.0 mm | 23: ID. 8.0, OD. 12.0 mm | 38: ID. 12.0, OD. 13.0 mm | 55: ID. 17.5, OD. 20.5 mm |
| 05: ID. 3.5, OD. 6.5 mm | 11: ID. 5.0, OD. 9.0 mm | 25: ID. 9.0, OD. 11.0 mm | 39: ID. 12.0, OD. 14.0 mm | 60: ID. 22.0, OD. 27.0 mm |
| 07: ID. 4.0, OD. 7.0 mm | 14: ID. 6.0, OD. 9.0 mm | 27: ID. 9.0, OD. 13.0 mm | 40: ID. 12.0, OD. 16.0 mm | |
| 08: ID. 4.5, OD. 6.5 mm | 17: ID. 7.0, OD. 9.0 mm | 33: ID. 10.0, OD. 14.0 mm | 43: ID. 13.0, OD. 15.0 mm | |
| 09: ID. 4.5, OD. 8.0 mm | 19: ID. 7.0, OD. 11.0 mm | 36: ID. 11.0, OD. 13.0 mm | 45: ID. 14.0, OD. 18.0 mm | |

Hose type:

- 1: Fuel hose
- 3: Vinyl hose
- 5: General hose

⊙ **CAUTION: It is DANGEROUS to confuse the fuel hose with the general purpose hose or vinyl hose.**

Never use a general purpose hose or vinyl hose in place of a fuel hose or vice versa. Always use the correct bulk part in the parts catalogue, according to the service manual or the instructions issued with the bulk part.

FLAT RATE SERVICE TIME

Flat rate service time (FRT) means the standard time required to service a product, which is listed in this manual to help the dealers control the actual working process and calculate the service charge by using it as a guide.

FRT setting system

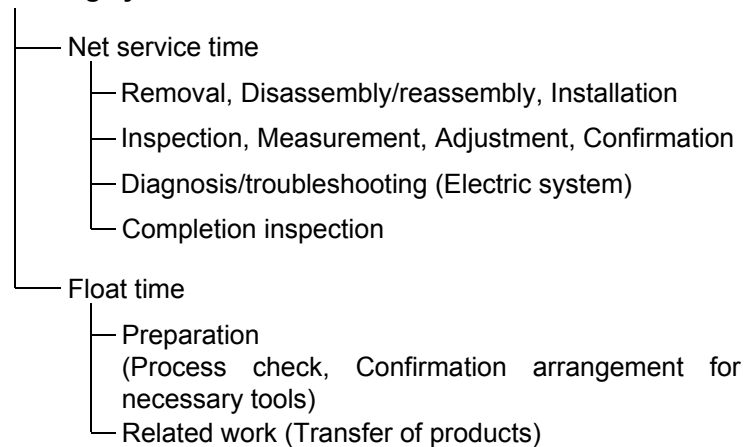

* Float time is set by multiplying the net service time by a given coefficient.

Editorial style

The service items shown in the text are listed with the exchange work time for the repair sales parts as the subject. Other representative service items not using repair parts (removal/installation, adjustment, inspection/measuring, and other work) are listed collectively in the list in the preface, classified according to the work.

FRT setting standard

- Decimal system (in unit of 0.1) is adopted to set FRT as it is convenient to calculate the wage.
Example: (0.1) → 6 minutes, (0.2) → 12 minutes
[Labor cost per hour] x [FRT] = [Wage]
- FRT is set with a hand tool.
- Service items and FRT can be subject to change depending on development of tools and service equipment and improvement in service procedure.

Work procedure

- As the work procedure is set with the work time according to the method in the separate Service Manual, refer to this Manual as required.
- Work methods permitting servicing in the shortest time still permitting assurance of safe work and product warranty are used for the setting of service items not listed in the Service Manual.
- Work basically is to be performed by one person, and when two or more people are required, setting is done as the total time for the number of people.
- The set value for the technological level of the workers uses a person with three years of experience in the repair of Honda products as the standard.
- Special tools and service equipment used to set FRT are those specified or recommended in Service Manual.

Service item whose FRT is not presented

- Accessories and service parts that are not listed to use in this manual.
 - Locations with little aging deterioration or breakage during normal use.
 - Service work that can be finished by one touch.
 - Service work that is seldom done (i.e. extremely small causes of trouble and service frequency).
 - Products and parts whose location for installation differs according to its status of use and application.
- * When FRT is not presented, please calculate wages based on appropriate actual work time.

Operation not included of FRT

- Oil and coolant water draining, Waiting time for warming up operation and etc..
- Additional operation that involves removal/installation of standard exterior equipment.
- Indirect time spent for service by visiting the customer, trade-in, and delivery.
- Indirect time required for ordering and delivery of parts.
- Cost for grease, adhesive agent, etc. used for service work.

**Explanation of FRT by using an example
(The example may differ from the actual presented items)**

Ref. No.	L.O.N.	(Relative ref. Number) Description	F.R.T.
①	1111L1	④ VALVE, INTAKE 4.1	②
②		⑧ • NOTE: OHV type	⑦
③	1111L1A	⑤ • Includes: Engine removal and installation One head (intake all) add 1.4	

- ① Reference No. of the illustration of part that shows location of the replacement work.
- ② FRT is an abbreviation of Flat Rate Time indicating the standard service time required for the replacement.
- ③ LON is an abbreviation of Labor Operation Number, and it is a classification of the service items by the work unit code.

The same operation code is used regardless of the models.

Standard operation is indicated with 6 digits code, and additional operation is indicated with 7 digits code.

- ④ Indicating the intake valve replacement and FRT4.1.
- ⑤ Indicating FRT1.4 that will be added when additional operation (whole intake side of one cylinder head) is done in association with intake valve replacement.

- ⑥ Indicating work condition or application condition of the service item.
- ⑦ Indicating work contents that are included in the service item.
- ⑧ Indicating a reference No. whose operation and time are the same as FRT4.1 for the intake valve.

(The application range is limited to the service items without an LON setting within a same block.)

**How to refer to the service item by using the sample
(intake valve replacement)**

Open to the page of the block where the intake valve's spare part illustration is shown.

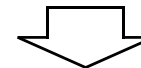

Look for the intake valve illustration, and refer to the service item and FRT that agree with the reference No.

Indication mark for the listing of service items that continues to the following page

Ref. No.	L.O.N.	(Relative ref. Number) Description	F.R.T.
2	1111L1	VALVE, INTAKE	4.1
	.	.	.
	.	.	.

+
Mark indicated at the last line.

Indication of the block with no setting of FRT

Ref. No.	L.O.N.	(Relative ref. Number) Description	F.R.T.
NO INFORMATION			

• LON code system

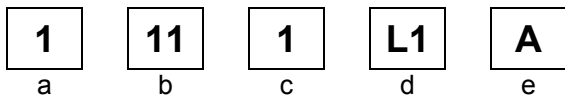

- a) Category code..... Engine
- b) Location/function code Engine upper
- c) Operation code..... Replace
- d) Operation sequence number (Unit code can be shown with alphabet)
..... Intake valve
(No regular rule of code)
- e) Additional code One head (intake all)
(No regular rule of code)

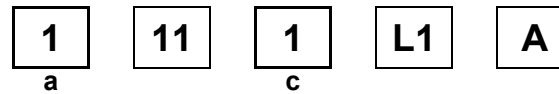

a) Category codes and classification

Code	Category
1	Engine
2	Power drive
3	Fuel & Exhaust
4	Frame & Body
5	Steering
6	Electrical
7	Axle & Brake
8	Control system
9	-
0	Attachments

c) Operation codes and classification

Code	Operation category
1	Replace, Removal/Installation, Change
2	Overhaul
3	Adjust, Rotation
4	(Paint-related work: Top-coat)
5	Test, Inspect/diagnose, Measurement
6	(Overhaul-related work: Rebore)
7	(Overhaul-related work: Reseal)
8	(Resurface)
9	(Paint-related work: Refinish)
0	Repair, Cleaning, Air bleeding

Major service items without using spare parts

- (1) Removal/Installation, (2) Adjustment,
(3) Inspection/Masurement, (4) Overhaul, (5) Other work

E: Engine, T: Transmission, D: Drive system,
B: Body and related parts

(1) Removal/Installation

Set with the parts configuration in the status of being removed from the product.

	LON	DESCRIPTION	FRT
E	1111L3	CYLINDER HEAD ASSEMBLY-REMOVAL/INSTALLATION	0.6

(2) Adjustment

	LON	DESCRIPTION	FRT
E	1113A1	VALVE CLEARANCE-ADJUSTMENT NOTE: For 1 product	0.3
	1163A0	CONTROL, THROTTLE/GOVERNOR-ADJUSTMENT	0.2
	3113A2	CARBURETOR IDLE-ADJUSTMENT	0.2

(3) Inspection, Measurement, Cleaning

	LON	DESCRIPTION	FRT
E	1105A0	ENGINE OIL-INSPECTION	0.1
	3120A0	AIR CLEANER-CLEANING INCLUDES: Air cleaner-inspection	0.2
	3130A0	SPARK ARRESTER-CLEANING	0.2
	6140A0	SPARK PLUG-ADJUSTMENT/CLEANING NOTE: For 1 product	0.1

(4) Overhaul

Work condition: The required Measurements, inspections, adjustments, and cleaning/washing of each part are performed, including the main body removal/installation work and the replacement of defective parts.

	LON	DESCRIPTION	FRT
E	3112A0	CARBURETOR-OVERHAUL INCLUDES: All necessary adjustment	0.6

(5) Other work

	LON	DESCRIPTION	FRT
E	1101E1	ENGINE OIL-CHANGE INCLUDES: Engine oil-inspection	0.2

ENGINE GROUP

B14

E-2

CYLINDER HEAD

C 1

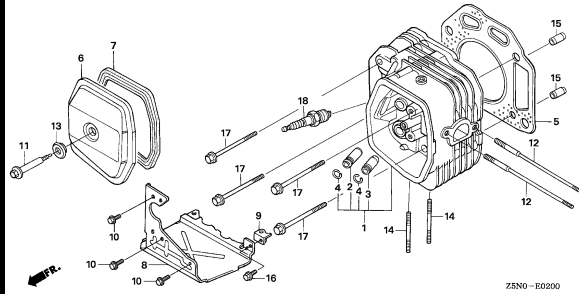

E-3

CYLINDER BARREL

C 2

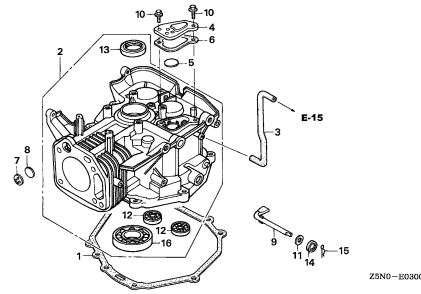

E-6

OIL PAN

C 3

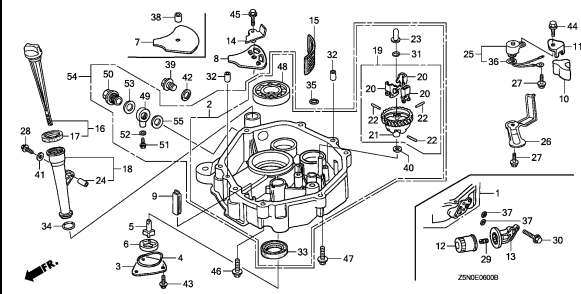

E-7

CRANKSHAFT

C 6

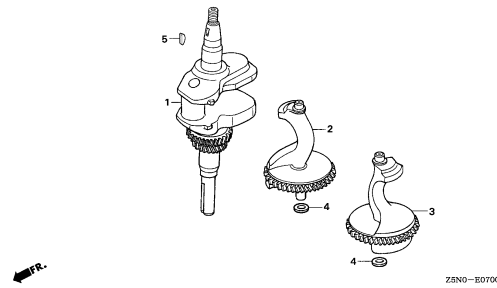

E-8

PISTON

C 7

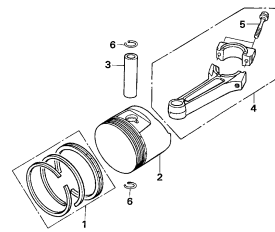

E-9

CAMSHAFT

C 9

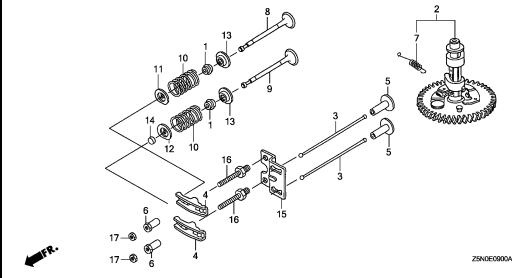

E-11

RECOIL STARTER

C12

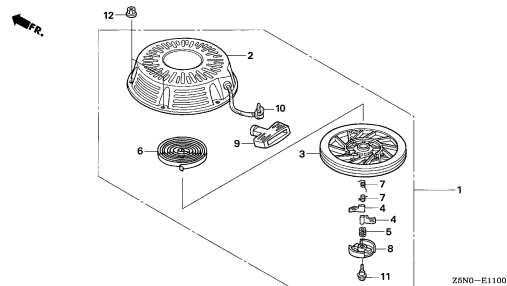

E-12

FAN COVER

C13

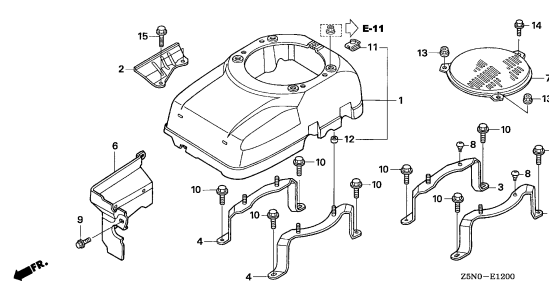

E-14

CARBURETOR(1)

C14

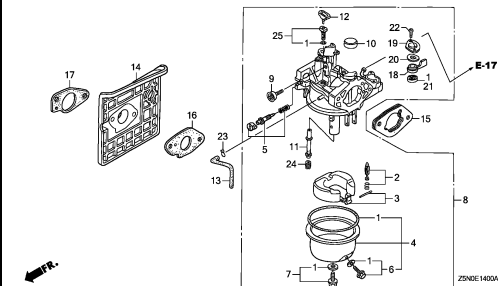

2

ENGINE GROUP

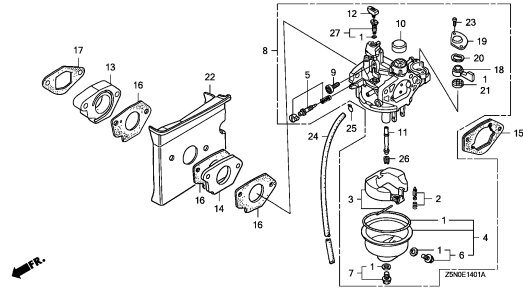
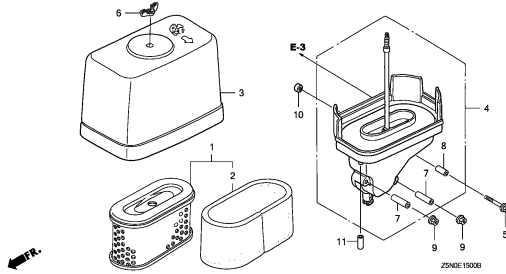
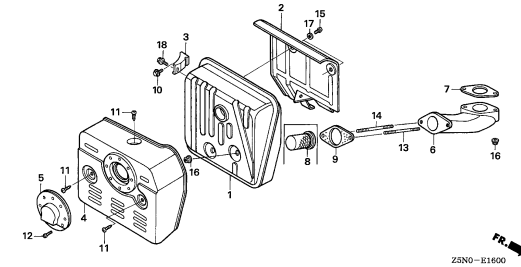
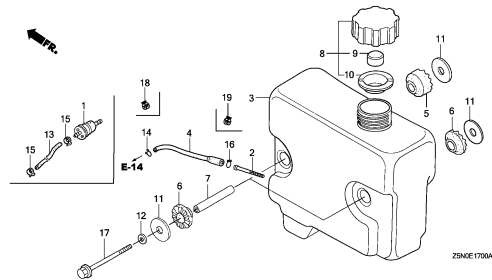
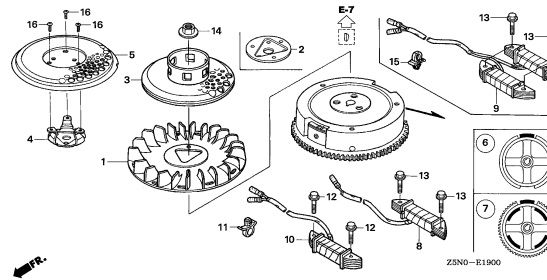
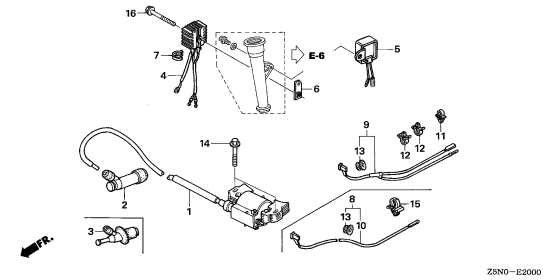
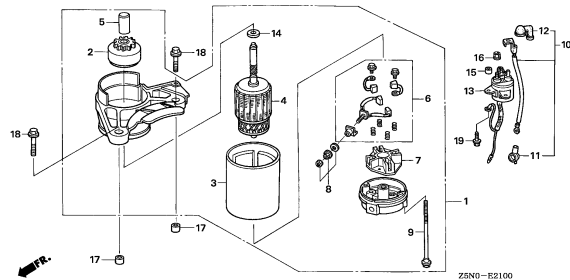
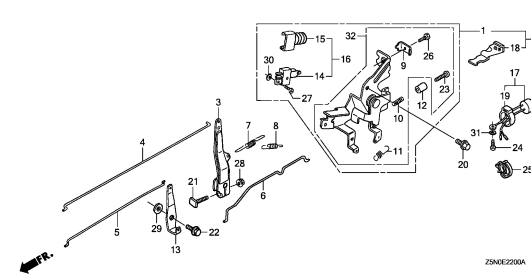
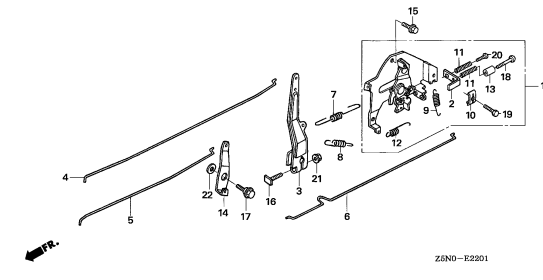
B15**E-14-1****CARBURETOR(2)****C16****E-15****AIR CLEANER****D 2****E-16****MUFFLER****D 3****E-17****FUEL TANK****D 4****E-19****FLYWHEEL****D 6****E-20****IGNITION COIL****D 7****E-21****STARTER MOTOR****D 8****E-22****CONTROL(1)****D 9****E-22-1****CONTROL(2)****D11****2**

ENGINE GROUP

B16

E-28

LABEL/TOOL

D12

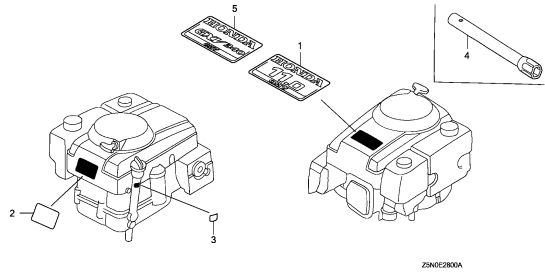

E-40

OTHER PARTS

D13

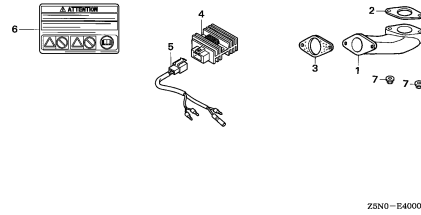

EOP-1

GASKET KIT

D14

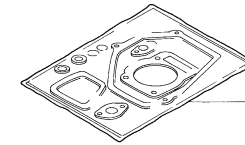

2

E-2

CYLINDER HEAD

C 1

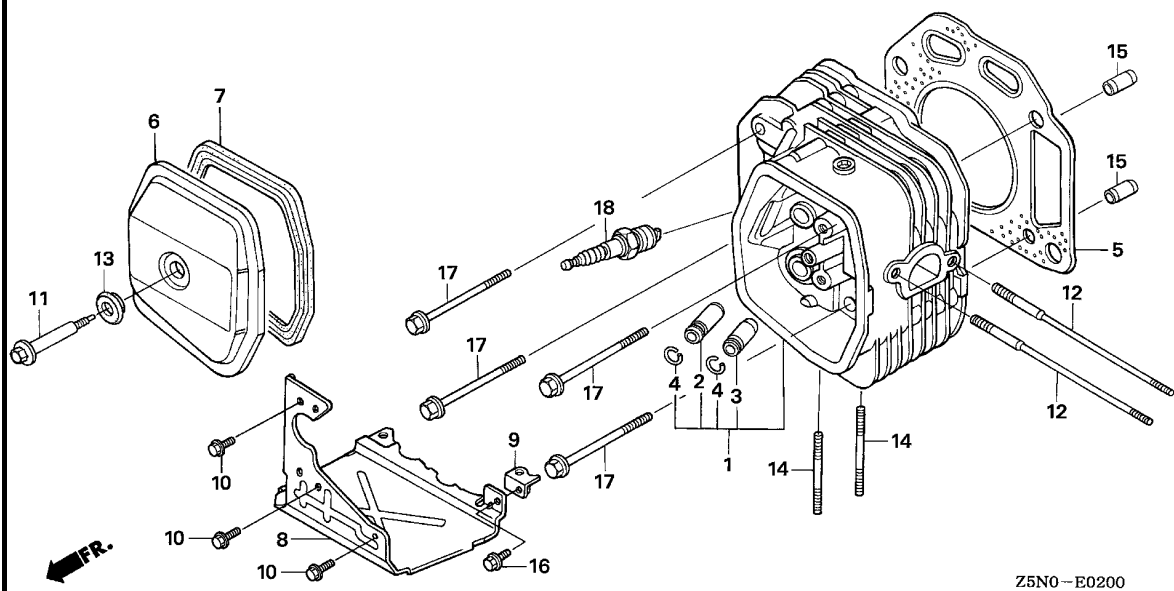

Ref. No.	L.O.N.	(Relative ref. Number) Description	F.R.T.
1	1111N3	HEAD, CYLINDERINCLUDES: Valve clearance adjustment and reface	1.0
2	1111E9	GUIDE, INTAKE VALVEINCLUDES: Valve clearance adjustment	0.8
	1111E9E	.Replace intake and exhaust all add	0.2
3	1111E8	GUIDE, EXHAUST VALVEINCLUDES: Valve clearance adjustment	0.8
	1111E8E	.Replace intake and exhaust all add	0.2
5	1111N4	GASKET, CYLINDER HEAD	0.6
6	1111D5	COVER, CYLINDER HEAD AND/OR PACKING, HEAD COVER	0.1
18	6141C1	PLUG, SPARKINCLUDES: Spark plug check	0.1

Z5N0-E0200

Ref. No.	Part No.	Description	Reqd. QTY		Serial No.	Parts catalogue code
			GXV 340 UT2	GXV 340 RT2		
1	12200-Z1E-405	HEAD COMP., CYLINDER	1	1		
2	12204-ZE2-306	GUIDE, IN. VALVE (O.S.)	1	1		
3	12205-ZE2-305	GUIDE, EX. VALVE (O.S.)	1	1		
4	12216-ZE2-300	CLIP, VALVE GUIDE	2	2		
5	12251-ZE9-600	GASKET, CYLINDER HEAD	1	-	1013558	
	12251-Z1F-801	1	-	1013559	
			-	1		
6	12310-ZE8-000	COVER, HEAD	1	1		
7	12391-ZE8-000	PACKING, HEAD COVER	1	1		
8	18345-ZF5-020	COVER, UNDER	1	1	-----	DA, DAS, DA2, DA23, DA33, DCAG, DET3, DE33, DNE4, DNG4, DN4, DXE2, DX2, DX3
9	18347-ZE8-000	STAY COMP., UNDER COVER	1	1	-----	DA, DAS, DA2, DA23, DA33, DCAG, DET3, DE33, DNE4, DNG4, DN4, DXE2, DX2, DX3
10	90013-883-000	BOLT, FLANGE, 6X12(CT200) ...	3	3	-----	DA, DAS, DA2, DA23, DA33, DCAG, DET3, DE33, DNE4, DNG4, DN4, DXE2, DX2, DX3
11	90014-ZE8-000	BOLT, HEAD COVER	1	1		
12	90042-ZE8-000	BOLT, STUD, 8X131.5	2	2	-----	DA, DAS, DA2, DA23, DA33, DCAG, DCA1, DET3, DE33, DNE4, DNG4, DN4, DXE2, DX2, DX3
	90042-ZE8-700	BOLT, STUD, 8X138.5	2	2	-----	DM33
13	90441-ZE2-010	WASHER COMP., HEAD COVER ...	1	1		
14	92900-08032-0B	BOLT, STUD, 8X32	2	2	-----	DA, DAS, DA2, DA23, DA33, DCAG, DCA1, DET3, DE33, DNE4, DNG4, DN4, DXE2, DX2, DX3
	92900-08022-0B	BOLT, STUD, 8X22	2	2	-----	DM33
15	94301-12200	DOWEL PIN, 12X20	2	2		
16	95701-06012-00	BOLT, FLANGE, 6X12	1	1	-----	DA, DAS, DA2, DA23, DA33, DCAG, DET3, DE33, DNE4, DNG4, DN4, DXE2, DX2, DX3
17	95701-10080-00	BOLT, FLANGE, 10X80	4	4		
18	98079-55876	PLUG, SPARK (BPR5ES)	1	1		

2

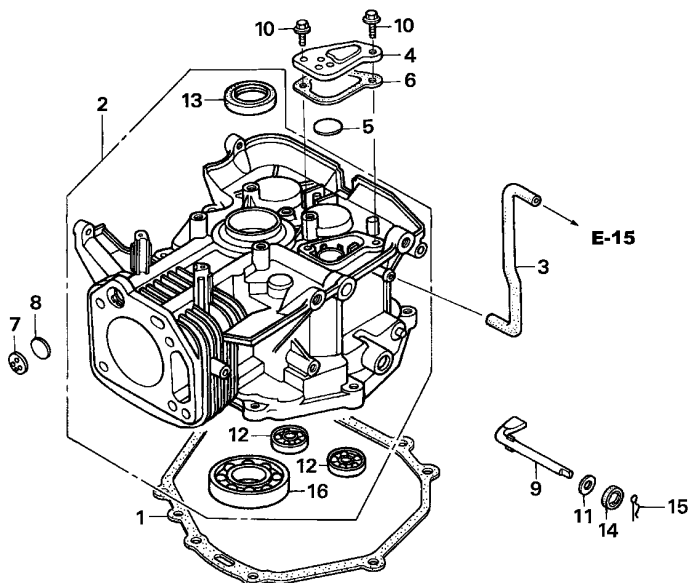

Z5N0-E0300

Ref. No.	L.O.N.	(Relative ref. Number) Description	F.R.T.
1	1131C2	PACKING, OIL PAN	0.2
2	1101A0	BARREL, CYLINDER	1.7
3	1111K5	TUBE, BREATHER	0.1
9	1161B4	SHAFT, GOVERNOR ARM	0.4
12	1101F7	BEARING, BALANCER WEIGHT :LEFT	0.5
	1101F7A	.Replace right balancer weight bearing add	0.1
	1101F8	BEARING, BALANCER WEIGHT :RIGHT	0.5
	1101F8A	.Replace left balancer weight bearing add	0.1
13	1101E6	OIL SEAL, CRANKSHAFT :UPPER ..	1.1
16	1101J6	BEARING, CRANKSHAFT :UPPER ...	1.2

Ref. No.	Part No.	Description	Reqd. QTY		Serial No.	Parts catalogue code
			GXV 340 UT2	GXV 340 RT2		
1	11381-ZE9-801	PACKING, OIL PAN	1	1		
2	12000-Z1F-405	BARREL ASSY., CYLINDER	1	1		
3	12315-ZF5-000	TUBE, BREATHER	1	1		
4	12370-ZF5-000	CAP, BREATHER CHAMBER	1	1		
5	12372-ZE2-300	VALVE, BREATHER	1	1		
6	12373-ZE8-000	PACKING, BREATHER CAP	1	1		
7	12375-ZE9-010	PLATE, ONE-WAY VALVE	1	1	-----	DA2,DA23,DA33,DCAG,DXE2,DX2
8	12376-ZE8-000	VALVE, ONE WAY	1	1	-----	DA2,DA23,DA33,DCAG,DXE2,DX2
9	16541-ZE8-010	SHAFT, GOVERNOR ARM	1	1		
10	90013-883-000	BOLT, FLANGE, 6X12(CT200) ...	2	2		
11	90406-VM6-000	WASHER, THRUST, 8.1MM	1	1		
12	91001-ZF5-003	BEARING, RADIAL BALL, 6202 ..	2	2		
13	91201-Z1C-003	OIL SEAL, 35X52X8	1	1		
14	91203-952-771	OIL SEAL, 8X14X5	1	1		
15	94251-10000	PIN, LOCK, 10MM	1	1		
16	96100-62073-00	BEARING, RADIAL BALL, 6207 ..	1	1		

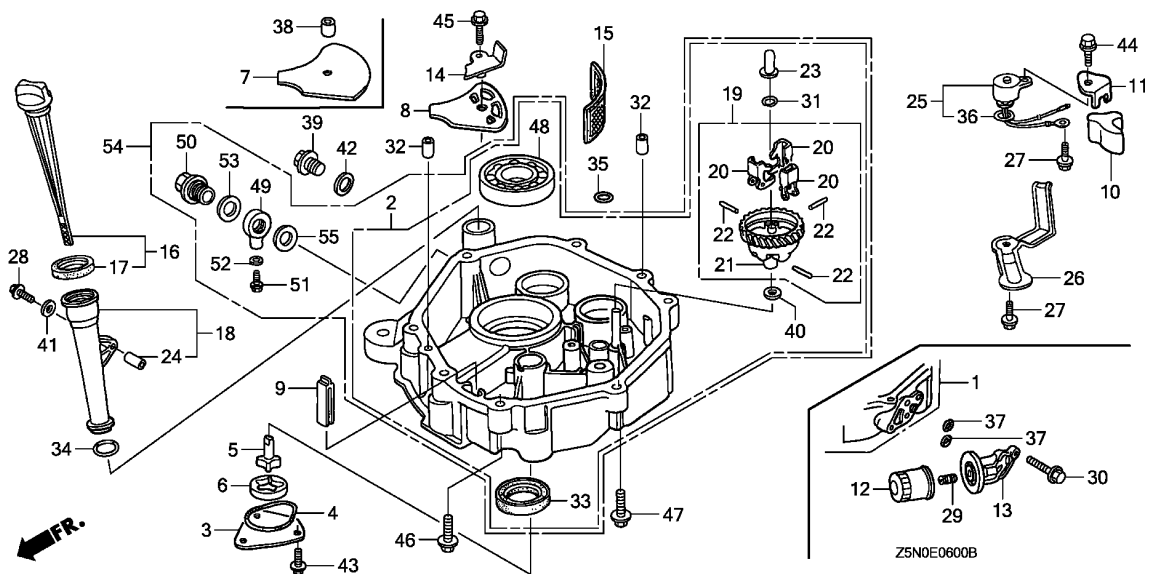

Ref. No.	L.O.N.	(Relative ref. Number) Description	F.R.T.
2	1131C1	PAN, OIL	0.3
5		(3,4,6)	
12	1131B2	ROTOR, OIL PUMP INNER	0.1
	110175	CARTRIDGE, OIL FILTER	0.1
		.EXCLUDES: Engine oil-change (37)	
13	1101A2	BASE, OIL FILTER	0.2
		(7,8)	
15	1101D2	SCREEN, OIL FILTER	0.3
18	1101B9	EXTENSION, OIL FILLER AND/OR PACKING, OIL FILLER EXTENSION	0.1
21		(20)	
	1161A7	HOLDER, GOVERNOR WEIGHT	0.3
	1161B6	SLIDER, GOVERNOR	0.4
	25	6151E8 SWITCH, OIL LEVEL	0.3
	33	1101E7 OIL SEAL, CRANKSHAFT :LOWER	0.4
	48	1101J7 BEARING, CRANKSHAFT :LOWER	0.4
	54	(1)	
	1131B0	PAN ASSEMBLY, OIL	0.3

Ref. No.	Part No.	Description	Reqd. QTY		Serial No.	Parts catalogue code
			GXV 340 UT2	GXV 340 RT2		
1	11300-Z1E-405	PAN ASSY., OIL	1	1	-----	DAS,DET3
	11300-Z1E-406	1	1	-----	DA23
2	11300-Z1E-407	PAN ASSY., OIL	1	1	-----	DA,DCAG,DCA1,DE33,DNE4,DNG4,DN4,DX3
	11300-Z1E-408	1	1	-----	DA2,DA33,DXE2,DX2
3	15130-ZE8-000	COVER, OIL PUMP	1	1	-----	
4	15131-ZE9-003	O-RING, PUMP COVER	1	1	-----	
5	15330-ZE8-000	ROTOR COMP., INNER	1	1	-----	
6	15332-891-003	ROTOR, OIL PUMP OUTER	1	1	-----	
7	15334-ZE8-010	PLATE, OIL FILTER	1	1	-----	DA,DAS,DCA1,DET3,DE33,DM33,DNE4,DNG4,DN4,DX3
8	15334-ZE8-811	PLATE, OIL FILTER	1	1	-----	DA2,DA23,DA33,DCAG,DXE2,DX2
9	15335-ZE9-000	RUBBER, OIL RETURN	1	1	-----	
10	15336-ZE8-000	STOPPER, OIL	1	1	-----	DA2,DA23,DA33,DCAG,DXE2,DX2
11	15337-ZE8-000	PLATE, OIL STOPPER	1	1	-----	DA2,DA23,DA33,DCAG,DXE2,DX2
12	15400-ZJ1-004	CARTRIDGE, OIL FILTER				
		(TOYO ROKI)	1	1	-----	DAS,DA23,DET3
13	15411-ZF5-W00	BASE, OIL FILTER	1	1	-----	DAS,DA23,DET3
14	15420-ZE8-000	PLATE COMP., SUCTION	1	1	-----	DA2,DA23,DA33,DCAG,DXE2,DX2
15	15421-ZE9-003	SCREEN, OIL FILTER	1	1	-----	
16	15600-ZF5-000	CAP ASSY., OIL FILLER	1	1	-----	
17	15625-ZE8-000	PACKING, OIL FILLER CAP	1	1	-----	
18	15630-ZE8-000	EXTENSION, OIL FILLER	1	1	-----	
19	16510-ZE3-000	GOVERNOR ASSY.	1	1	-----	
20	16511-ZE8-000	WEIGHT, GOVERNOR	3	3	-----	
21	16512-ZE3-000	HOLDER, GOVERNOR WEIGHT	1	1	-----	
22	16513-ZE2-000	PIN, GOVERNOR WEIGHT	3	3	-----	



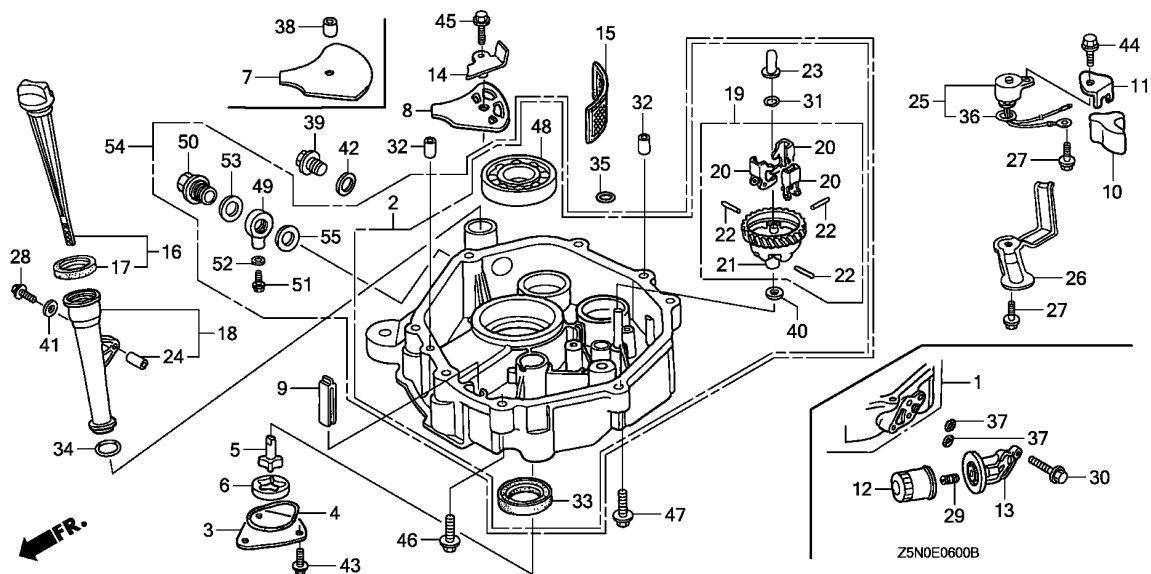

Ref. No.	Part No.	Description	Reqd. QTY		Serial No.	Parts catalogue code
			GXV 340 UT2	GXV 340 RT2		
23	16531-Z0A-000	SLIDER, GOVERNOR	1	1		
24	17240-ZE6-000	COLLAR, EXTENSION	1	1		
25	35410-ZF5-013	SWITCH COMP., OIL LEVEL	1	1	-----	----- DA2,DA23,DA33,DCAG,DXE2,DX2
26	35419-ZF5-000	PROTECTOR, SWITCH	1	1	-----	----- DA2,DA23,DA33,DCAG,DXE2,DX2
27	90013-883-000	BOLT, FLANGE, 6X12(CT200) ...	2	2	-----	----- DA2,DA23,DA33,DCAG,DXE2,DX2
28	90014-ZE6-000	BOLT, FLANGE, 6X35(CT200) ...	1	1		
29	90018-PN3-000	HOLDER, OIL FILTER	1	1	-----	----- DAS,DA23,DET3
30	90121-952-000	BOLT, FLANGE, 6X25(CT200) ...	2	2	-----	----- DAS,DA23,DET3
31	90602-ZE1-000	CLIP, GOVERNOR HOLDER	1	1		
32	90701-HC4-000	DOWEL PIN, 8X12	2	2		
33	91201-Z1C-003	OIL SEAL, 35X52X8	1	1		
34	91301-ZE9-003	O-RING, 22.5X2.2	1	1		
35	91302-ZE9-003	O-RING, 11.8X2.4	1	1		
36	91302-ZL8-003	O-RING, 11.8X2.4	1	1	-----	----- DA2,DA23,DA33,DCAG,DXE2,DX2
37	91303-HA0-004	O-RING, 11X1.9(NOK)	2	2	-----	----- DAS,DA23,DET3
38	91501-ZF5-000	COLLAR, OIL FILTER SETTING ..	1	1	-----	----- DA,DAS,DCA1,DET3,DE33,DM33,DNE4,DNG4,DN4,DX3
39	92800-20000	BOLT, DRAIN PLUG, 20MM	1	1	-----	----- DA,DAS,DA2,DA23,DA33,DCAG,DCA1,DET3,DE33,DNE4,DNG4,DN4,DXE2,DX2,DX3
40	94101-06800	WASHER, PLAIN, 6MM	1	1		
41	94103-06700	WASHER, PLAIN, 6MM	1	1	-----	----- DA,DA2,DA23,DA33,DCAG,DCA1,DM33,DNE4,DNG4,DN4,DXE2,DX2,DX3
42	94109-20000	WASHER, DRAIN PLUG, 20MM ...	1	1	-----	----- DA,DAS,DA2,DA23,DA33,DCAG,DCA1,DET3,DE33,DNE4,DNG4,DN4,DXE2,DX2,DX3
43	95701-06012-00	BOLT, FLANGE, 6X12	3	3		
44	95701-06016-00	BOLT, FLANGE, 6X16	1	1	-----	----- DA2,DA23,DA33,DCAG,DXE2,DX2
45	95701-06025-00	BOLT, FLANGE, 6X25	1	1		
46	95701-08040-08	BOLT, FLANGE, 8X40	6	6		

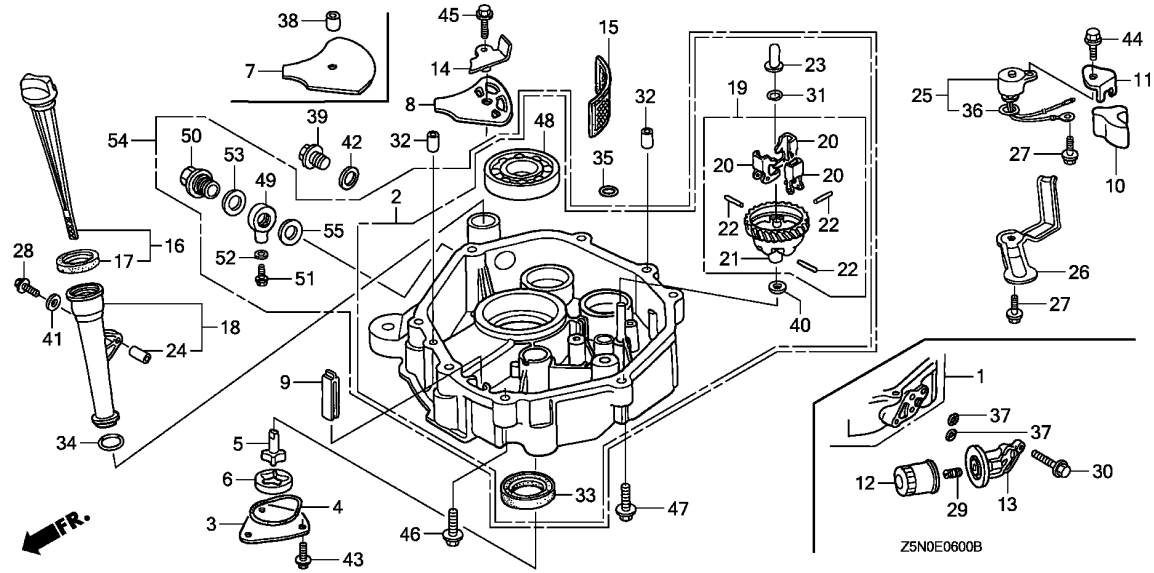

Ref. No.	Part No.	Description	Reqd. QTY		Serial No.	Parts catalogue code
			GXV 340 UT2	GXV 340 RT2		
47	95701-08060-08	BOLT, FLANGE, 8X60	1	1		
48	96100-62073-00	BEARING, RADIAL BALL, 6207 ..	1	1		
49	15642-ZF5-L00	JOINT, OIL DRAIN	1	1	-----	DM33
50	90031-ZF5-L00	BOLT, OIL JOINT	1	1	-----	DM33
51	90131-ZE1-000	BOLT, DRAIN PLUG	1	1	-----	DM33
52	90601-ZE1-000	WASHER, DRAIN PLUG, 10.2MM ..	1	1	-----	DM33
53	90601-ZF5-L00	WASHER, OIL DRAIN, 24MM	1	1	-----	DM33
54	11300-Z1E-Q00	PAN ASSY., OIL	1	1	-----	DM33
55	94109-20000	WASHER, DRAIN PLUG, 20MM	1	1	-----	DM33



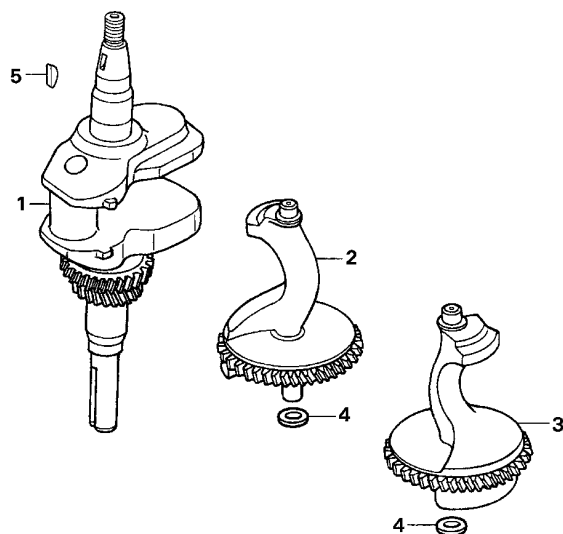

Z5N0-E0700

FR.

Ref. No.	L.O.N.	(Relative ref. Number) Description	F.R.T.
1	1101F0	CRANKSHAFT	1.1
2	1101K2	WEIGHT A, BALANCER	0.4
	1101K2A	.Replace one balancer weight add	0.1
3	1101K3	WEIGHT B, BALANCER	0.4
	1101K3A	.Replace one balancer weight add	0.1

Ref. No.	Part No.	Description	Reqd. QTY		Serial No.	Parts catalogue code
			GXV 340 UT2	GXV 340 RT2		
1	13310-ZF5-040	CRANKSHAFT COMP.	1	1		
2	13351-ZE9-603	WEIGHT A, BALANCER	1	1		
3	13356-ZE9-604	WEIGHT B, BALANCER	1	1		
4	90417-HA0-000	WASHER, THRUST, 15MM	2	2		
5	90741-ZE2-000	KEY, SPECIAL WOODRUFF, 25X18	1	1		

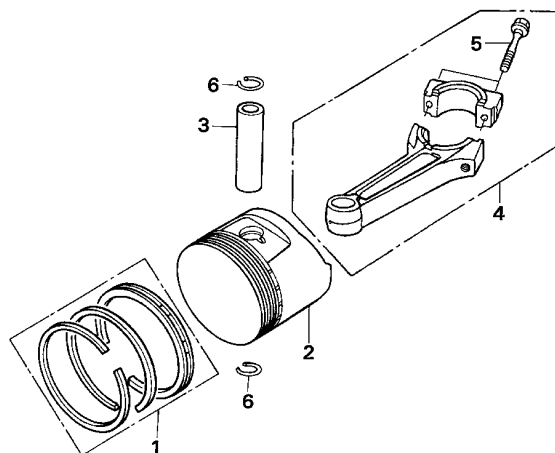

Z5N0-E0800

Ref. No.	L.O.N.	(Relative ref. Number) Description	F.R.T.
2	1111R1	(1,3,4) PISTON AND/OR RING SET AND/OR BEARING AND/OR RODINCLUDES: Inspection/ Measurement/Cleaning	1.2

Ref. No.	Part No.	Description	Reqd. QTY		Serial No.	Parts catalogue code
			GXV 340 UT2	GXV 340 RT2		
1	13010-Z1F-800	RING SET, PISTON (STD.)(RIKEN)	1	-	-----	1020361
	13011-Z1F-800	RING SET, PISTON (0.25)(RIKEN)	(1)	-	-----	1020361
	13012-Z1F-800	RING SET, PISTON (0.50)(RIKEN)	(1)	-	-----	1020361
	13013-Z1F-800	RING SET, PISTON (0.75)(RIKEN)	(1)	-	-----	1020361
	13010-Z5L-004	RING SET, PISTON (STD.) (TEIKOKU)	1	-	1020362	
			-	1		
	13010-Z5N-003	RING SET, PISTON (STD.)(RIKEN)	1	-	1020362	
			-	1		
	13011-Z5L-004	RING SET, PISTON (0.25) (TEIKOKU)	(1)	-	1020362	
			-	(1)		
	13011-Z5N-003	RING SET, PISTON (0.25)(RIKEN)	(1)	-	1020362	
			-	(1)		
	13012-Z5L-004	RING SET, PISTON (0.50) (TEIKOKU)	(1)	-	1020362	
			-	(1)		
	13012-Z5N-003	RING SET, PISTON (0.50)(RIKEN)	(1)	-	1020362	
			-	(1)		
	13013-Z5L-004	RING SET, PISTON (0.75) (TEIKOKU)	(1)	-	1020362	
			-	(1)		
	13013-Z5N-003	RING SET, PISTON (0.75)(RIKEN)	(1)	-	1020362	
			-	(1)		
2	13101-ZE3-W00	PISTON (STD.)	1	-	-----	1020361
	13102-ZE3-W00	PISTON (0.25)	(1)	-	-----	1020361
	13103-ZE3-W00	PISTON (0.50)	(1)	-	-----	1020361
	13104-ZE3-W00	PISTON (0.75)	(1)	-	-----	1020361



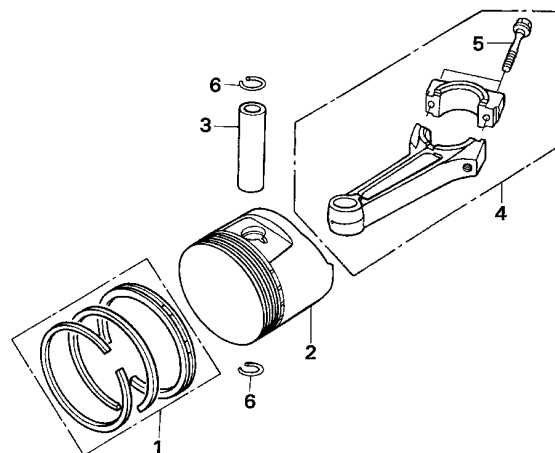

Z5N0-E0800

Ref. No.	Part No.	Description	Reqd. QTY		Serial No.	Parts catalogue code
			GXV 340 UT2	GXV 340 RT2		
(2)	13101-ZE3-W01	PISTON (STD.)	1	-	1020362	
	13102-ZE3-W01	PISTON (0.25)	(1)	-	1020362	
	13103-ZE3-W01	PISTON (0.50)	(1)	-	1020362	
	13104-ZE3-W01	PISTON (0.75)	(1)	-	1020362	
3	13111-ZE3-000	PIN, PISTON	1	1		
4	13200-Z1E-000	ROD ASSY., CONNECTING (STD.)	1	1		
	13200-Z1E-305	ROD ASSY., CONNECTING (0.25 UNDER SIZE)	(1)	(1)		
5	90001-ZE8-000	BOLT, CONNECTING ROD	2	2		
6	90601-ZE3-000	CLIP, PISTON PIN, 20MM	2	2		

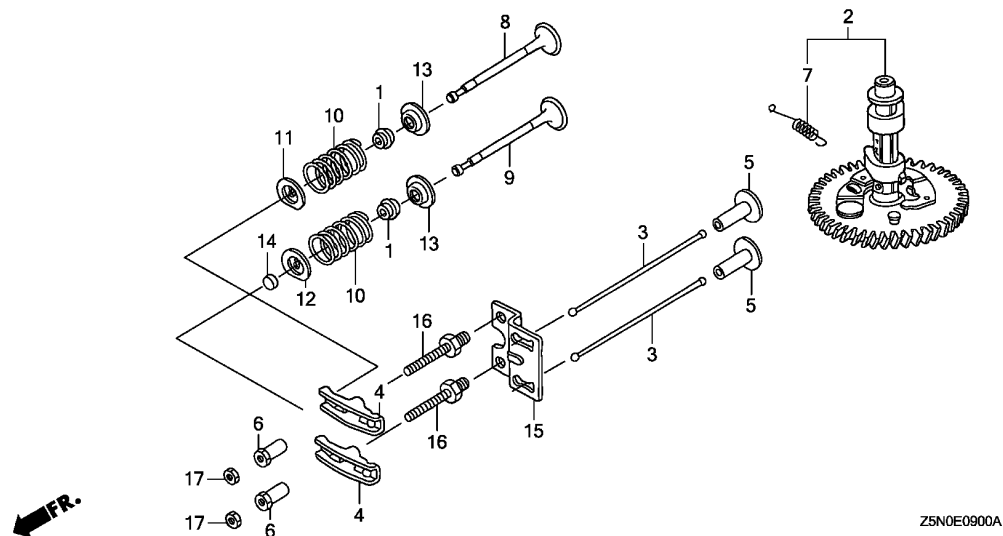

Ref. No.	L.O.N.	(Relative ref. Number) Description	F.R.T.
1	1111K2	SEAL, INTAKE VALVE STEMINCLUDES: Valve clearance adjustment	0.6
	1111K2E	.Replace intake and exhaust all add	0.1
	1111K1	SEAL, EXHAUST VALVE STEMINCLUDES: Valve clearance adjustment	0.6
	1111K1E	.Replace intake and exhaust all add	0.1
2	1111C2	CAMSHAFT	0.6
3	1111L6	ROD, PUSH :INTAKE	0.2
	1111L6A	.Replace exhaust push rod add	0.1
	1111L7	ROD, PUSH :EXHAUST	0.2
	1111L7A	.Replace intake push rod add	0.1
4	1111A2	ARM, ROCKER :INTAKE	0.2
	1111A2A	.Replace exhaust rocker arm add	0.1
+	1111A1	ARM, ROCKER :EXHAUST	0.2

Ref. No.	Part No.	Description	Reqd. QTY		Serial No.	Parts catalogue code
			GXV 340 UT2	GXV 340 RT2		
1	12209-ZE8-003	SEAL, VALVE STEM	2	2		
2	14100-ZE8-602	CAMSHAFT ASSY.	1	1		
3	14410-Z1C-000	ROD, PUSH	2	2		
4	14431-ZE2-010	ARM, VALVE ROCKER	2	2		
5	14441-ZE2-000	LIFTER, VALVE	2	2		
6	14451-ZE1-013	PIVOT, ROCKER ARM	2	2		
7	14568-ZE1-000	SPRING, WEIGHT RETURN	1	1		
8	14711-ZE3-000	VALVE, IN.	1	1		
9	14721-ZE3-000	VALVE, EX.	1	1		
10	14751-Z1C-000	SPRING, VALVE	2	2		
11	14771-ZE2-000	RETAINER, IN. VALVE SPRING ..	1	1		
12	14773-ZE2-000	RETAINER, EX. VALVE SPRING ..	1	1		
13	14775-ZE2-010	SEAT, VALVE SPRING	2	2		
14	14781-ZE2-000	ROTATOR, VALVE	1	1		
15	14791-ZE9-010	GUIDE, PUSH ROD	1	1		
16	90012-ZE0-010	BOLT, PIVOT, 8MM	2	2		
17	90206-ZE1-000	NUT, PIVOT ADJUSTING	2	2		



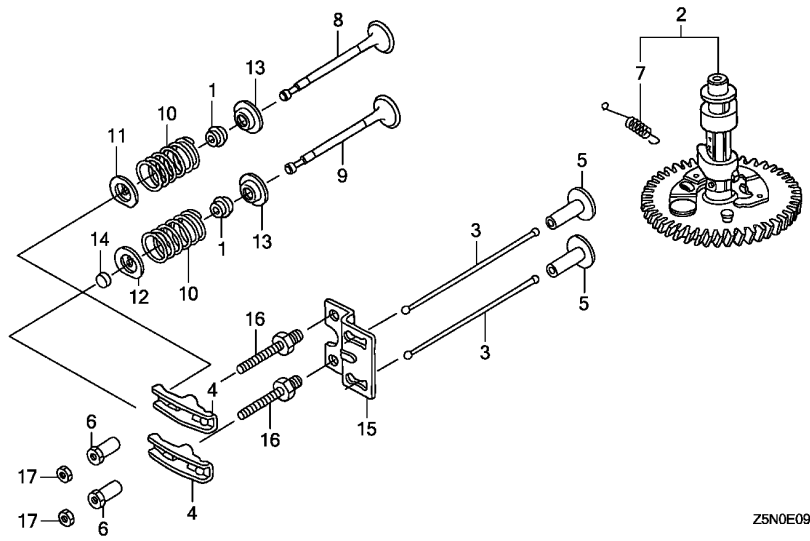

Ref. No.	L.O.N.	(Relative ref. Number) Description	F.R.T.
+ 4		.INCLUDES: Valve clearance adjustment	
1111A1A		.Replace intake rocker arm add	0.1
5 1111L9		LIFTER, VALVE :INTAKEINCLUDES: Valve clearance adjustment	0.6
1111M0		.NOTE: Same time for two units LIFTER, VALVE :EXHAUSTINCLUDES: Valve clearance adjustment	0.6
8 1111L1		.NOTE: Same time for two units VALVE, INTAKEINCLUDES: Valve clearance adjustment and reface	0.7
1111L1E		.Replace intake and exhaust all add	0.1
9 1111L0		VALVE, EXHAUSTINCLUDES: Valve clearance adjustment and reface	0.7
1111L0E		.Replace intake and exhaust all add	0.1
10 1111P3		SPRING, VALVE :INTAKEINCLUDES: Valve clearance adjustment	0.6
+			



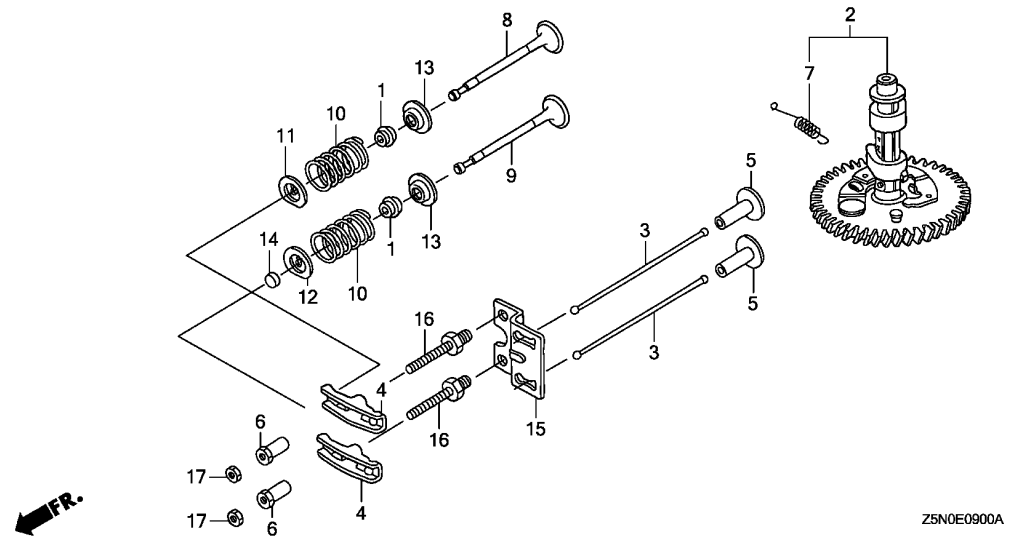

Ref. No.	L.O.N.	(Relative ref. Number) Description	F.R.T.
+10	1111P3A	.Replace intake and exhaust all add	0.1
	1111P4	SPRING, VALVE :EXHAUSTINCLUDES: Valve clearance adjustment	0.6
	1111P4A	.Replace intake and exhaust all add	0.1
14	1111J7	ROTATOR, VALVEINCLUDES: Valve clearance adjustment	0.2



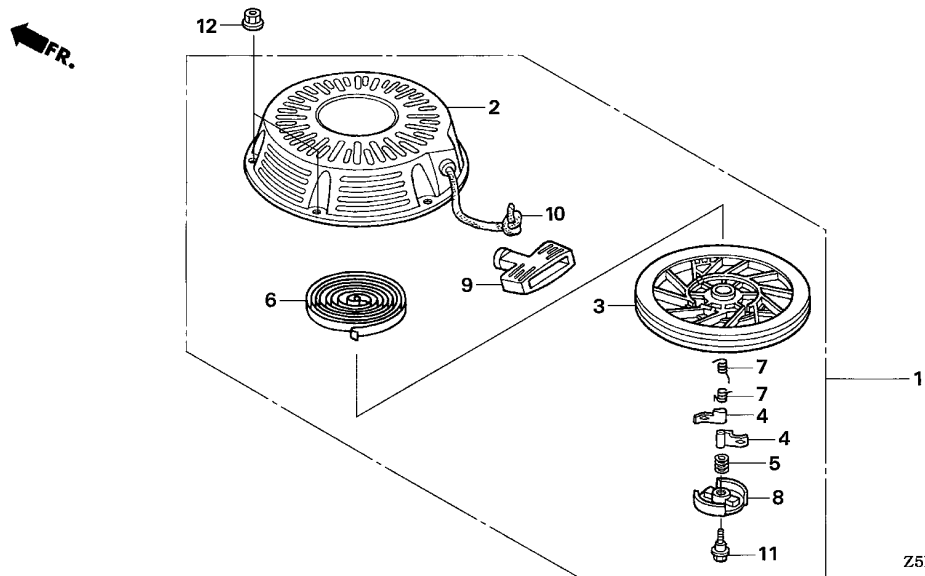

Ref. No.	L.O.N.	(Relative ref. Number) Description	F.R.T.
1	1121B9	STARTER, RECOIL	0.1
3	1121B1	REEL, RECOIL STARTER	0.3
4		(7)	
	1121B0	RATCHET, STARTER AND/OR SPRING, RATCHET	0.2
6	1121B7	SPRING, RECOIL STARTER RETURN	0.3
10	1121B3	ROPE, RECOIL STARTER	0.3

2

Ref. No.	Part No.	Description	Reqd. QTY		Serial No.	Parts catalogue code
			GXV 340 UT2	GXV 340 RT2		
1	28400-ZE3-W01ZB	STARTER ASSY., RECOIL				
		NH1.....BLACK	1	1	-----	DAS,DA33,DNE4,DNG4
	28400-ZE3-W01ZP	*R280*.....POWER RED	1	1	-----	DA,DA2,DA23,DA33,DET3,DE33,DNE4,DN4,DXE2,DX2,DX3
2	28410-ZE3-W01ZB	CASE COMP., RECOIL STARTER				
		NH1.....BLACK	1	1	-----	DAS,DA33,DNE4,DNG4
	28410-ZE3-W01ZP	*R280*.....POWER RED	1	1	-----	DA,DA2,DA23,DA33,DET3,DE33,DNE4,DN4,DXE2,DX2,DX3
3	28421-ZE3-W01	PULLEY, RECOIL STARTER	1	1	-----	DA,DAS,DA2,DA23,DA33,DET3,DE33,DNE4,DNG4,DN4,DXE2,DX2,DX3
4	28422-ZE2-W01	RATCHET, STARTER	2	2	-----	DA,DAS,DA2,DA23,DA33,DET3,DE33,DNE4,DNG4,DN4,DXE2,DX2,DX3
5	28441-ZE2-W01	SPRING, FRICTION	1	1	-----	DA,DAS,DA2,DA23,DA33,DET3,DE33,DNE4,DNG4,DN4,DXE2,DX2,DX3
6	28442-ZE2-W01	SPRING, STARTER RETURN	1	1	-----	DA,DAS,DA2,DA23,DA33,DET3,DE33,DNE4,DNG4,DN4,DXE2,DX2,DX3
7	28443-ZE2-W01	SPRING, RATCHET	2	2	-----	DA,DAS,DA2,DA23,DA33,DET3,DE33,DNE4,DNG4,DN4,DXE2,DX2,DX3
8	28444-ZE2-W01	RETAINER, SPRING	1	1	-----	DA,DAS,DA2,DA23,DA33,DET3,DE33,DNE4,DNG4,DN4,DXE2,DX2,DX3
9	28461-ZE2-W02	GRIP, STARTER	1	1	-----	DA,DAS,DA2,DA23,DA33,DET3,DE33,DNE4,DNG4,DN4,DXE2,DX2,DX3
10	28462-ZE3-W01	ROPE, RECOIL STARTER	1	1	-----	DA,DAS,DA2,DA23,DA33,DET3,DE33,DNE4,DNG4,DN4,DXE2,DX2,DX3
11	90004-ZE2-W01	SCREW, CENTER	1	1	-----	DA,DAS,DA2,DA23,DA33,DET3,DE33,DNE4,DNG4,DN4,DXE2,DX2,DX3
12	94050-06000	NUT, FLANGE, 6MM	4	4	-----	DA,DAS,DA2,DA23,DA33,DET3,DE33,DNE4,DNG4,DN4,DXE2,DX2,DX3

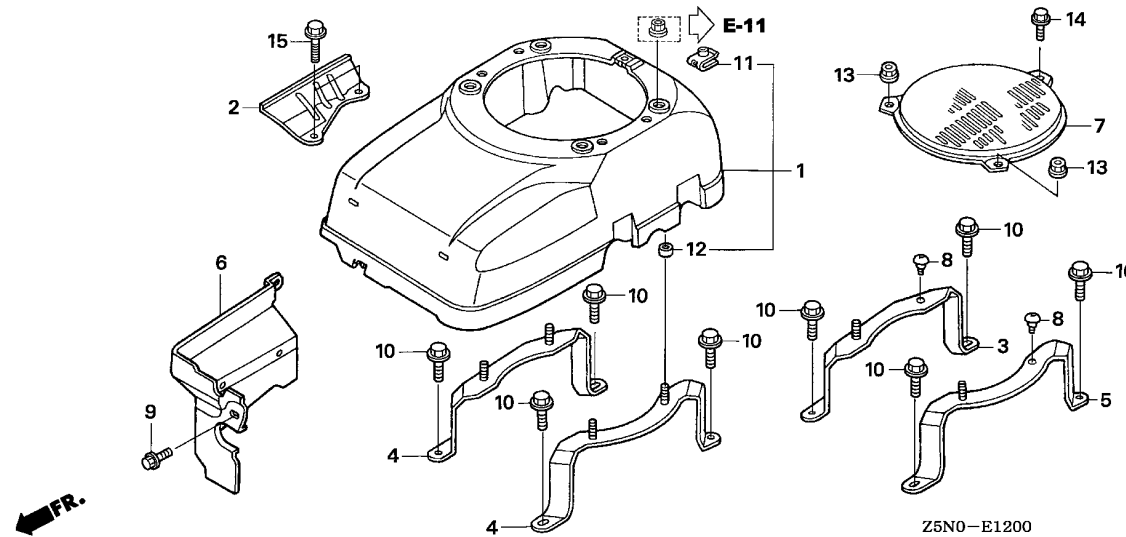

Ref. No.	L.O.N.	(Relative ref. Number) Description	F.R.T.
1	1141G8	COVER, ENGINE COOLING FAN (3,5)	0.2
4	1141K9	BRACKET, FAN COVER :LEFT	0.2
	1141L0	BRACKET, FAN COVER :RIGHT	0.2

Ref. No.	Part No.	Description	Reqd. QTY		Serial No.	Parts catalogue code
			GXV 340 UT2	GXV 340 RT2		
1	19610-ZE9-V01ZC	COVER COMP., FAN				
		R280.....POWER RED	1	1	-----	DCAG,DCA1,DM33
	19610-ZF5-V11ZA	*NH1*.....BLACK	1	1	-----	DAS,DNE4
	19610-ZF5-V11ZC	*R280*.....POWER RED	1	1	-----	DET3,DE33,DNE4,DXE2
	19610-ZF5-V21ZA	*NH1*.....BLACK	1	1	-----	DA33,DNG4
	19610-ZF5-V21ZC	*R280*.....POWER RED	1	1	-----	DA,DA2,DA23,DA33,DN4,DX2,DX3
2	19612-ZF5-010	PLATE, SIDE	1	1	-----	DA,DA2,DA23,DA33,DNG4,DN4,DX2,DX3
3	19617-ZE9-V00	BRACKET, R. FAN COVER	1	1	-----	DCAG,DCA1,DM33
4	19617-ZF5-V00	BRACKET, FAN COVER	2	2	-----	DA,DAS,DA2,DA23,DA33,DET3,DE33,DNE4,DNG4,DN4,DXE2,DX2,DX3
5	19627-ZE9-V00	BRACKET, L. FAN COVER	1	1	-----	DCAG,DCA1,DM33
6	19631-Z1E-V00	SHROUD	1	1	-----	DCA1,DM33
7	28456-ZF5-V00ZA	COVER, SCREEN GRID				
		NH1.....BLACK	1	1	-----	DCAG,DCA1,DM33
8	90006-ZF5-V00	SCREW, SPECIAL, 6X8	2	2	-----	DCAG,DCA1,DM33
9	90013-883-000	BOLT, FLANGE, 6X12(CT200)	2	2	-----	DCA1,DM33
10	90029-888-000	BOLT, FLANGE, 6X16(CT200)	4	4	-----	
11	90320-747-000	NUT, SPRING, 6MM	1	1	-----	DCAG,DCA1,DM33
12	91501-ZF5-V00	COLLAR, FAN COVER	2	2	-----	DCAG,DCA1,DM33
			4	4	-----	DA,DAS,DA2,DA23,DA33,DET3,DE33,DNE4,DNG4,DN4,DXE2,DX2,DX3
13	94050-06000	NUT, FLANGE, 6MM	2	2	-----	DCAG,DCA1,DM33
14	95701-06010-00	BOLT, FLANGE, 6X10	1	1	-----	DCAG,DCA1,DM33
15	95701-08020-08	BOLT, FLANGE, 8X20	2	2	-----	DA,DA2,DA23,DA33,DNG4,DN4,DX2,DX3

E-14

CARBURETOR(1)

C14

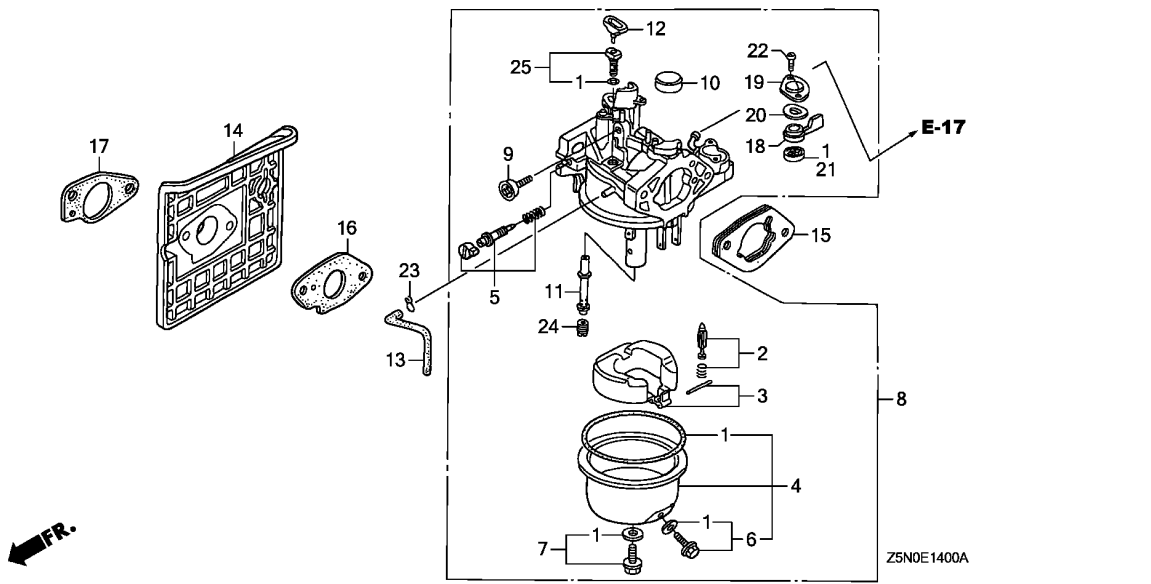

Ref. No.	L.O.N.	(Relative ref. Number) Description	F.R.T.
1	3111B1	GASKET SET, CARBURETOR	0.3
2	3111E1	VALVE SET, FLOAT AND/OR FLOAT SET	0.3
4	3111A3	CHAMBER SET, FLOAT AND/OR GASKET, FLOAT CHAMBER	0.2
5	3111D7	SCREW SET, PILOT	0.2
8	3111F3	CARBURETOR	0.2
14	3111C0	INSULATOR, CARBURETOR AND/OR PACKING, INSULATOR	0.2
16	3111C8	PACKING, CARBURETOR	0.2
21	3101C5	PACKING, FUEL COCK	0.2
24	3111C3	JET, MAIN	0.3

Ref. No.	Part No.	Description	Reqd. QTY		Serial No.	Parts catalogue code
			GXV 340 UT2	GXV 340 RT2		
1	16010-ZE2-015	GASKET SET (EXCEPT 16173-001-004)	1	1	-----	DA, DAS, DA2, DA23, DA33, DCAG, DCA1, DET3, DE33, DNE4, DNG4, DN4, DXE2, DX2, DX3
2	16011-ZA0-931	VALVE SET, FLOAT	1	1	-----	DA, DAS, DA2, DA23, DA33, DCAG, DCA1, DET3, DE33, DNE4, DNG4, DN4, DXE2, DX2, DX3
3	16013-Z1C-003	FLOAT SET	1	1	-----	DA, DAS, DA2, DA23, DA33, DCAG, DCA1, DET3, DE33, DNE4, DNG4, DN4, DXE2, DX2, DX3
4	16015-ZE8-005	CHAMBER SET, FLOAT	1	1	-----	DA, DAS, DA2, DA23, DA33, DCAG, DCA1, DET3, DE33, DNE4, DNG4, DN4, DXE2, DX2, DX3
5	16016-ZH7-W01	SCREW SET, PILOT	1	1	-----	DA, DAS, DA2, DA23, DA33, DCAG, DCA1, DET3, DE33, DNE4, DNG4, DN4, DXE2, DX2, DX3
6	16024-ZE1-811	SCREW SET, DRAIN	1	1	-----	DA, DAS, DA2, DA23, DA33, DCAG, DCA1, DET3, DE33, DNE4, DNG4, DN4, DXE2, DX2, DX3
7	16028-ZE0-005	SCREW SET	1	1	-----	DA, DAS, DA2, DA23, DA33, DCAG, DCA1, DET3, DE33, DNE4, DNG4, DN4, DXE2, DX2, DX3
8	16100-Z1F-W01	CARBURETOR ASSY. (BE81H A)	1	1	-----	DA, DAS, DA2, DA23, DA33, DCAG, DCA1, DET3, DE33, DNE4, DNG4, DN4, DXE2, DX2, DX3
9	16124-ZE0-005	SCREW, THROTTLE STOP	1	1	-----	DA, DAS, DA2, DA23, DA33, DCAG, DCA1, DET3, DE33, DNE4, DNG4, DN4, DXE2, DX2, DX3
10	16148-141-881	CAP, CHOKE DUST	1	1	-----	DA, DAS, DA2, DA23, DA33, DCAG, DCA1, DET3, DE33, DNE4, DNG4, DN4, DXE2, DX2, DX3
11	16166-ZE9-W01	NOZZLE, MAIN	1	1	-----	DA, DAS, DA2, DA23, DA33, DCAG, DCA1, DET3, DE33, DNE4, DNG4, DN4, DXE2, DX2, DX3
12	16172-ZE3-W10	COLLAR, SETTING	1	1	-----	DA, DAS, DA2, DA23, DA33, DCAG, DCA1, DET3, DE33, DNE4, DNG4, DN4, DXE2, DX2, DX3
13	16199-ZE8-000	TUBE, AIR VENT (75MM)	1	1	-----	DA, DAS, DA2, DA23, DA33, DCA1, DET3, DE33, DNE4, DNG4, DN4, DXE2, DX2, DX3
14	16211-ZE9-601	INSULATOR, CARBURETOR	1	1	-----	DA, DAS, DA2, DA23, DA33, DCAG, DCA1, DET3, DE33, DNE4, DNG4, DN4, DXE2, DX2, DX3
15	16220-ZA0-702	SPACER COMP., CARBURETOR	1	1	-----	DA, DAS, DA2, DA23, DA33, DCAG, DCA1, DET3, DE33, DNE4, DNG4, DN4, DXE2, DX2, DX3
16	16221-ZE3-800	PACKING, CARBURETOR	1	1	-----	DA, DAS, DA2, DA23, DA33, DCAG, DCA1, DET3, DE33, DNE4, DNG4, DN4, DXE2, DX2, DX3
17	16223-ZE9-800	PACKING, INSULATOR	1	1	-----	DA, DAS, DA2, DA23, DA33, DCAG, DCA1, DET3, DE33, DNE4, DNG4, DN4, DXE2, DX2, DX3
18	16953-ZE1-712	LEVER, COCK	1	1	-----	DA, DAS, DA2, DA23, DA33, DCAG, DCA1, DET3, DE33, DNE4, DNG4, DN4, DXE2, DX2, DX3
19	16954-ZE1-812	PLATE, LEVER SETTING	1	1	-----	DA, DAS, DA2, DA23, DA33, DCAG, DCA1, DET3, DE33, DNE4, DNG4, DN4, DXE2, DX2, DX3
20	16956-ZE1-811	SPRING, COCK LEVER	1	1	-----	DA, DAS, DA2, DA23, DA33, DCAG, DCA1, DET3, DE33, DNE4, DNG4, DN4, DXE2, DX2, DX3
21	16957-ZE1-812	PACKING, FUEL COCK	1	1	-----	DA, DAS, DA2, DA23, DA33, DCAG, DCA1, DET3, DE33, DNE4, DNG4, DN4, DXE2, DX2, DX3
22	93500-03006-1H	SCREW, PAN, 3X6	2	2	-----	DA, DAS, DA2, DA23, DA33, DCAG, DCA1, DET3, DE33, DNE4, DNG4, DN4, DXE2, DX2, DX3
23	95002-02080	CLIP, TUBE (B8)	1	1	-----	DA, DAS, DA2, DA23, DA33, DCA1, DET3, DE33, DNE4, DNG4, DN4, DXE2, DX2, DX3
24	99101-ZH8-0880	JET, MAIN, #88	(1)	(1)	-----	DA, DAS, DA2, DA23, DA33, DCAG, DCA1, DET3, DE33, DNE4, DNG4, DN4, DXE2, DX2, DX3

2

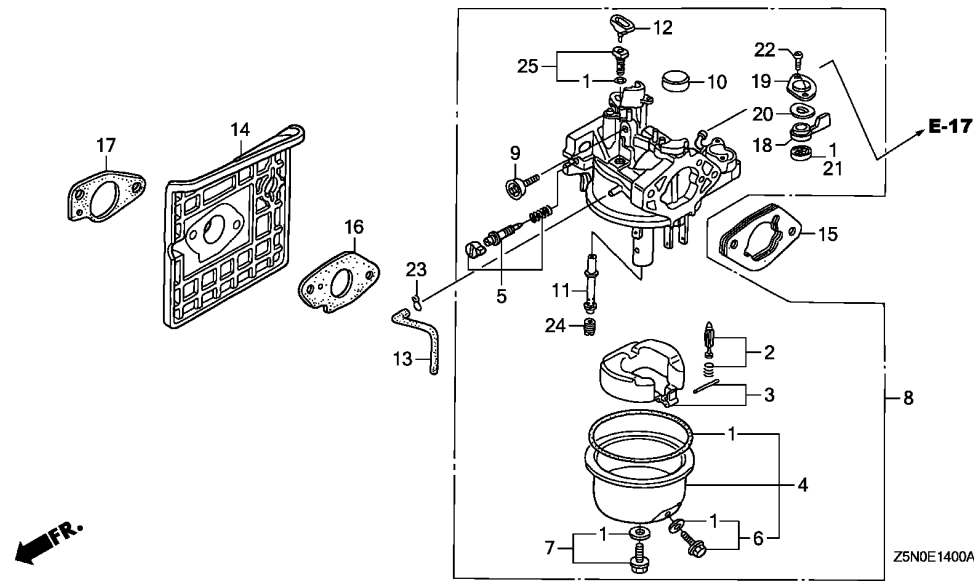

Ref. No.	Part No.	Description	Reqd. QTY		Serial No.	Parts catalogue code
			GXV 340 UT2	GXV 340 RT2		
24)	99101-ZH8-0900	JET, MAIN, #90	(1)	(1)	-----	DA,DAS,DA2,DA23,DA33,DCAG,DCA1,DET3,DE33,DNE4,DNG4,DN4,DXE2,DX2,DX3
	99101-ZH8-0920	JET, MAIN, #92	1	1	-----	DA,DAS,DA2,DA23,DA33,DCAG,DCA1,DET3,DE33,DNE4,DNG4,DN4,DXE2,DX2,DX3
25	99204-ZE0-0380	JET SET, PILOT, #38	1	1	-----	DA,DAS,DA2,DA23,DA33,DCAG,DCA1,DET3,DE33,DNE4,DNG4,DN4,DXE2,DX2,DX3

E-14-1

CARBURETOR(2)

C16

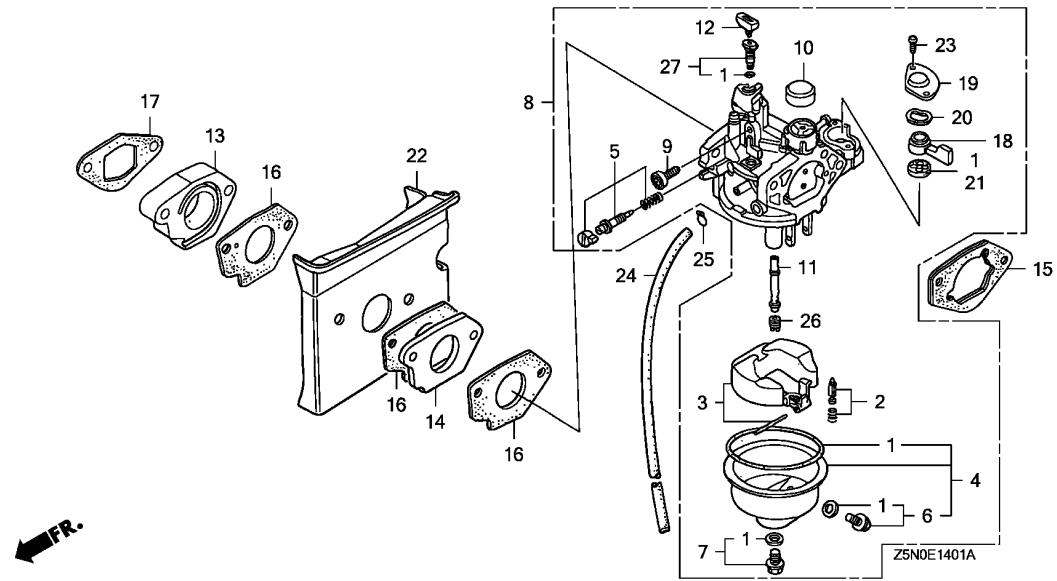

Ref. No.	L.O.N.	(Relative ref. Number) Description	F.R.T.
1	3111B1	GASKET SET, CARBURETOR (3)	0.3
2	3111E1	VALVE SET, FLOAT AND/OR FLOAT SET	0.3
4	3111A3	CHAMBER SET, FLOAT AND/OR GASKET, FLOAT CHAMBER	0.2
5	3111D7	SCREW SET, PILOT	0.2
8	3111F3	CARBURETOR (14,17)	0.2
13	3111C0	INSULATOR, CARBURETOR AND/OR PACKING, INSULATOR	0.2
16	3111C8	PACKING, CARBURETOR NOTE: Same time for two units or more	0.2
21	3101C5	PACKING, FUEL COCK (18,19,20)	0.2
26	3111C3	JET, MAIN	0.3

Ref. No.	Part No.	Description	Reqd. QTY		Serial No.	Parts catalogue code
			GXV 340 UT2	GXV 340 RT2		
1	16010-ZE2-015	GASKET SET (EXCEPT 16173-001-004)	1	1	----- DM33	
2	16011-ZA0-931	VALVE SET, FLOAT	1	1	----- DM33	
3	16013-ZA0-931	FLOAT SET	1	1	----- DM33	
4	16015-ZE8-005	CHAMBER SET, FLOAT	1	1	----- DM33	
5	16016-ZH7-W01	SCREW SET, PILOT	1	1	----- DM33	
6	16024-ZE1-811	SCREW SET, DRAIN	1	1	----- DM33	
7	16028-ZE0-005	SCREW SET	1	1	----- DM33	
8	16100-ZE9-L72	CARBURETOR ASSY. (BE81B C)	1	1	----- DM33	
9	16124-ZE0-005	SCREW, THROTTLE STOP	1	1	----- DM33	
10	16148-141-881	CAP, CHOKE DUST	1	1	----- DM33	
11	16166-ZE9-W01	NOZZLE, MAIN	1	1	----- DM33	
12	16172-ZE3-W10	COLLAR, SETTING	1	1	----- DM33	
13	16211-ZE9-010	INSULATOR, CARBURETOR	1	1	----- DM33	
14	16211-ZE9-L00	INSULATOR, CARBURETOR	1	1	----- DM33	
15	16220-ZA0-702	SPACER COMP., CARBURETOR	1	1	----- DM33	
16	16221-ZE3-800	PACKING, CARBURETOR	3	3	----- DM33	
17	16223-ZE9-800	PACKING, INSULATOR	1	1	----- DM33	
18	16953-ZE1-712	LEVER, COCK	1	1	----- DM33	
19	16954-ZE1-812	PLATE, LEVER SETTING	1	1	----- DM33	
20	16956-ZE1-811	SPRING, COCK LEVER	1	1	----- DM33	
21	16957-ZE1-812	PACKING, FUEL COCK	1	1	----- DM33	
22	19625-ZE9-L00	GUIDE, AIR	1	1	----- DM33	
23	93500-03006-1H	SCREW, PAN, 3X6	2	2	----- DM33	

2

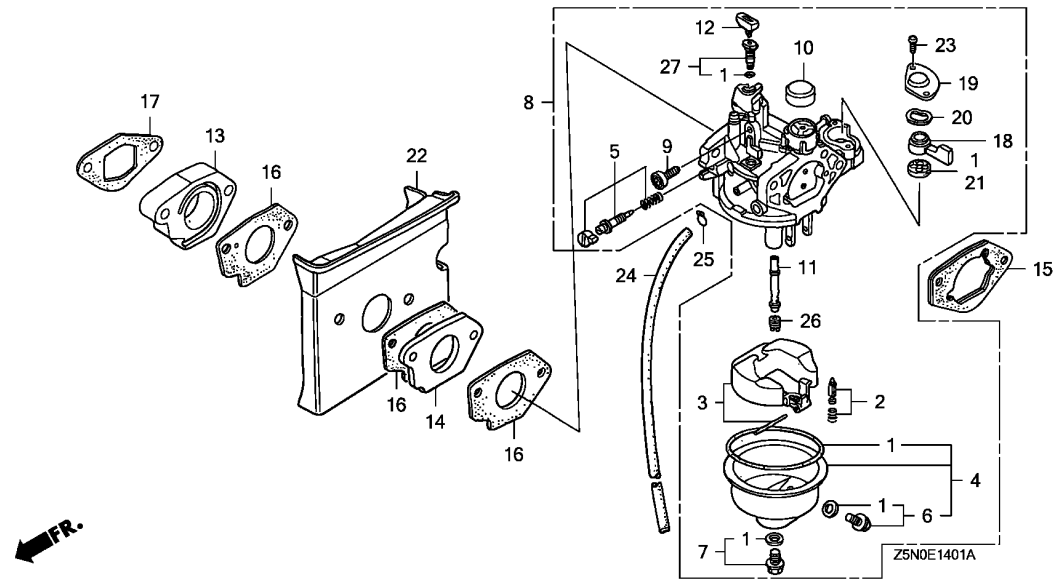

Ref. No.	Part No.	Description	Reqd. QTY		Serial No.	Parts catalogue code
			GXV 340 UT2	GXV 340 RT2		
24	95001-45180-30	TUBE, FUEL, 4.5X180 (95001-45001-60M)	1	1	-----	DM33
25	95002-02080	CLIP, TUBE (B8)	1	1	-----	DM33
26	99101-ZH8-0880	JET, MAIN, #88	(1)	(1)	-----	DM33
	99101-ZH8-0900	JET, MAIN, #90	(1)	(1)	-----	DM33
	99101-ZH8-0920	JET, MAIN, #92	1	1	-----	DM33
27	99204-ZE0-0380	JET SET, PILOT, #38	1	1	-----	DM33

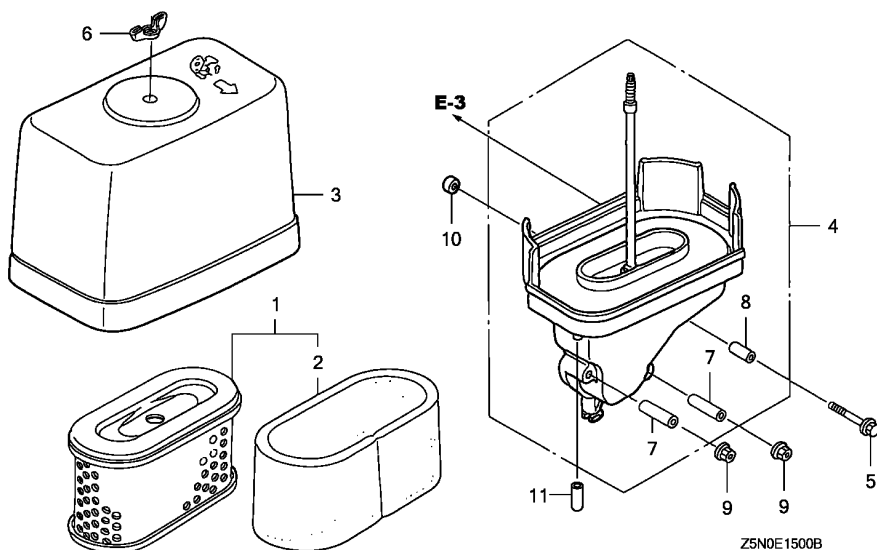

Ref. No.	L.O.N.	(Relative ref. Number) Description	F.R.T.
1	3121B8	ELEMENT, AIR CLEANER	0.1
2	3121C1	FILTER, OUTER	0.1
4	3121B4	ELBOW, AIR CLEANER	0.1

Ref. No.	Part No.	Description	Reqd. QTY		Serial No.	Parts catalogue code
			GXV 340 UT2	GXV 340 RT2		
1	17211-ZF5-V01	ELEMENT, AIR CLEANER	1	-	1005632	
	17210-Z1E-801	ELEMENT COMP., AIR CLEANER ..	1	-	1005633	
2	17218-ZF5-V00	FILTER, OUTER	-	1	1005632	
3	17231-ZF5-V00	COVER, AIR CLEANER	1	1		
4	17410-ZF5-V00	ELBOW COMP., AIR CLEANER	1	-	1005632	
	17410-Z1E-801	1	-	1005633	
	17410-Z5V-000	-	1		
5	90014-ZE6-000	BOLT, FLANGE, 6X35(CT200) ...	1	1	-----	DA, DAS, DA2, DA23, DA33, DCAG, DCA1, DET3, DE33, DNE4, DNG4, DN4, DXE2, DX2, DX3
	90016-ZE8-000	BOLT, FLANGE, 6X45(CT200) ...	1	1	-----	DM33
6	90325-044-000	NUT, TOOL BOX SETTING	1	1		
7	91502-ZF5-V00	COLLAR, AIR CLEANER	2	2		
8	91503-ZF5-V00	COLLAR, AIR CLEANER	1	1		
9	94050-06000	NUT, FLANGE, 6MM	2	2		
10	17239-ZE8-700	SPACER, AIR CLEANER ELBOW ...	1	1	-----	DM33
11	90634-ZL8-H00	CAP, SEALING	-	1		

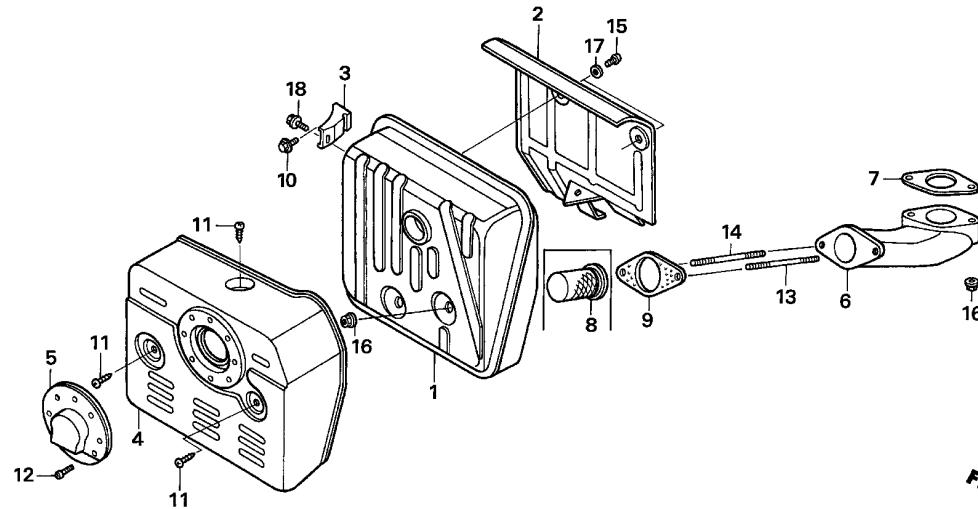

Ref. No.	L.O.N.	(Relative ref. Number) Description	F.R.T.
1	3131C5	MUFFLER, EXHAUST	0.2
2	3131J7	SEPARATOR, MUFFLER	0.2
4	3131D6	PROTECTOR, EXHAUST MUFFLER ...	0.1
6	3131C9	PIPE, EXHAUST	0.2
8	3131A1	ARRESTER, SPARK	0.2
9	3131B5	GASKET, EXHAUST PIPE	0.2

Ref. No.	Part No.	Description	Reqd. QTY		Serial No.	Parts catalogue code
			GXV 340 UT2	GXV 340 RT2		
1	18310-Z1E-000	MUFFLER COMP.	1	1	-----	DA,DAS,DA2,DA23,DA33,DCAG,DET3,DE33,DNE4,DNG4,DN4,DXE2,DX2,DX3
2	18316-ZF5-V00	SEPARATOR, MUFFLER	1	1	-----	DA,DAS,DA2,DA23,DA33,DCAG,DET3,DE33,DNE4,DNG4,DN4,DXE2,DX2,DX3
3	18318-ZE8-000	STAY COMP., MUFFLER	1	1	-----	DA,DAS,DA2,DA23,DA33,DCAG,DET3,DE33,DNE4,DNG4,DN4,DXE2,DX2,DX3
4	18321-ZF5-000	PROTECTOR, MUFFLER	1	1	-----	DA,DAS,DA2,DA23,DA33,DET3,DE33,DNE4,DNG4,DN4,DXE2,DX2,DX3
5	18331-ZE2-810	CAP, MUFFLER	1	1	-----	DA,DAS,DA2,DA23,DA33,DET3,DE33,DXE2,DX2,DX3
6	18331-ZF5-000	PIPE, EX.	1	1	-----	DA,DAS,DA2,DA23,DA33,DCAG,DET3,DE33,DNE4,DNG4,DN4,DXE2,DX2,DX3
7	18333-ZE3-800	GASKET, EX. PIPE	1	-	-----	DA,DAS,DA2,DA23,DA33,DCAG,DET3,DE33,DNE4,DNG4,DN4,DXE2,DX2,DX3
	18333-Z1C-801	-	1	-----	DA,DAS,DA2,DA23,DA33,DCAG
8	18335-ZE8-000	ARRESTER, SPARK	1	-	-----	DXE2,DX2,DX3
9	18382-ZE9-800	GASKET, EX. PIPE	1	-	-----	DA,DAS,DA2,DA23,DA33,DCAG,DET3,DE33,DNE4,DNG4,DN4,DXE2,DX2,DX3
	18382-Z1F-801	-	1	-----	DA,DAS,DA2,DA23,DA33,DCAG
10	90031-883-000	BOLT, FLANGE, 8X16	1	1	-----	DA,DAS,DA2,DA23,DA33,DCAG,DET3,DE33,DNE4,DNG4,DN4,DXE2,DX2,DX3
11	90050-ZE1-000	SCREW, TAPPING, 5X8	3	3	-----	DA,DAS,DA2,DA23,DA33,DCAG,DET3,DE33,DNE4,DNG4,DN4,DXE2,DX2,DX3
12	90055-ZE1-000	SCREW, TAPPING, 4X6	3	3	-----	DA,DAS,DA2,DA23,DA33,DET3,DE33,DXE2,DX2,DX3
13	92900-08060-1B	BOLT, STUD, 8X60	1	1	-----	DA,DAS,DA2,DA23,DA33,DCAG,DET3,DE33,DNE4,DNG4,DN4,DXE2,DX2,DX3
14	92900-08070-1B	BOLT, STUD, 8X70	1	1	-----	DA,DAS,DA2,DA23,DA33,DCAG,DET3,DE33,DNE4,DNG4,DN4,DXE2,DX2,DX3
15	93500-06006-0A	SCREW, PAN, 6X6	3	3	-----	DA,DAS,DA2,DA23,DA33,DCAG,DET3,DE33,DNE4,DNG4,DN4,DXE2,DX2,DX3
16	94050-08000	NUT, FLANGE, 8MM	4	4	-----	DA,DAS,DA2,DA23,DA33,DCAG,DET3,DE33,DNE4,DNG4,DN4,DXE2,DX2,DX3
17	94101-06000	WASHER, PLAIN, 6MM	3	3	-----	DA,DAS,DA2,DA23,DA33,DCAG,DET3,DE33,DNE4,DNG4,DN4,DXE2,DX2,DX3
18	95701-08014-00	BOLT, FLANGE, 8X14	1	1	-----	DA,DAS,DA2,DA23,DA33,DCAG,DET3,DE33,DNE4,DNG4,DN4,DXE2,DX2,DX3

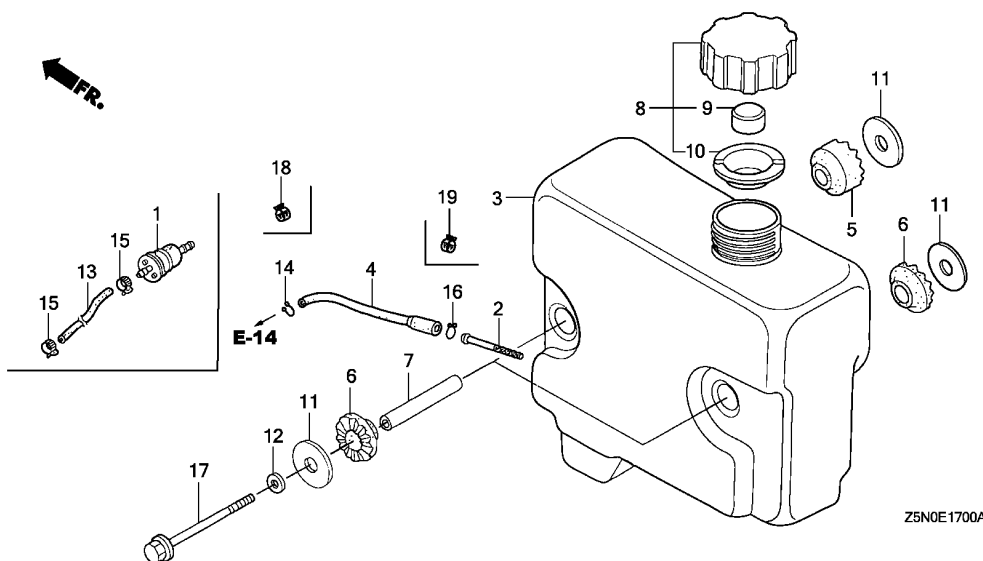

Ref. No.	L.O.N.	(Relative ref. Number) Description	F.R.T.
1	3101H8	STRAINER, FUEL	0.1
2	3101H6	JOINT, FUEL STRAINER	0.2
3	3101H7	TANK, FUEL	0.2
4	3101F1	TUBE, FUEL TANK	0.2
5	3101M0	RUBBER B, TANK MOUNTING	0.1
		.NOTE: Same time for two units or more	
13	3101B1	HOSE, FUEL	0.2

Ref. No.	Part No.	Description	Reqd. QTY		Serial No.	Parts catalogue code
			GXV 340 UT2	GXV 340 RT2		
1	16910-ZE8-015	STRAINER COMP., FUEL	1	1	-----	DA, DAS, DA2, DA23, DA33, DCA1
2	16952-ZE6-000	STRAINER, FUEL	1	-	-----	DET3, DE33, DNE4, DNG4, DN4, DXE2, DX2, DX3
3	17510-ZE9-000	TANK, FUEL	1	-	1020386	DET3, DE33, DNE4, DNG4, DN4, DXE2, DX2, DX3
	17511-Z5N-000	1	-	1020387	DET3, DE33, DNE4, DNG4, DN4, DXE2, DX2, DX3
4	17512-ZE9-000	TUBE, FUEL	1	-	1004989	DET3, DE33, DNE4, DNG4, DN4, DXE2, DX2, DX3
	17512-Z5N-003	TUBE, FUEL (FKM)	1	-	1004990	DET3, DE33, DNE4, DNG4, DN4, DXE2, DX2, DX3
5	17516-ZE8-000	RUBBER B, TANK MOUNTING	1	-	-----	DET3, DE33, DNE4, DNG4, DN4, DXE2, DX2, DX3
6	17516-896-700	RUBBER B, TANK MOUNTING	3	-	-----	DET3, DE33, DNE4, DNG4, DN4, DXE2, DX2, DX3
7	17518-ZE8-000	COLLAR, TANK SETTING	2	-	-----	DET3, DE33, DNE4, DNG4, DN4, DXE2, DX2, DX3
8	17620-ZE7-000	CAP ASSY., FUEL TANK	1	-	-----	DET3, DE33, DNE4, DNG4, DN4, DXE2, DX2, DX3
9	17622-888-010	SPONGE, FUEL CAP BREATHER	1	-	-----	DET3, DE33, DNE4, DNG4, DN4, DXE2, DX2, DX3
10	17624-ZE7-000	PACKING, FUEL CAP	1	-	-----	DET3, DE33, DNE4, DNG4, DN4, DXE2, DX2, DX3
11	90455-896-700	WASHER, TANK MOUNTING	4	-	-----	DET3, DE33, DNE4, DNG4, DN4, DXE2, DX2, DX3
12	90471-SB0-000	WASHER, PLAIN, 8MM	2	-	-----	DET3, DE33, DNE4, DNG4, DN4, DXE2, DX2, DX3
13	95001-45130-20	HOSE, FUEL, 4.5X130 (95001-45001-50M)	1	-	1004499	DCA1
	95001-45180-40	TUBE, FUEL, 4.5X180 (95001-45001-60M)	1	-	1013445	DCAG
	95001-45230-50	HOSE, FUEL, 4.5X230 (95001-45001-50M)	1	-	-----	DAS
	95001-45360-20	HOSE, FUEL, 4.5X360 (95001-45001-50M)	1	-	1013307	DA, DA2, DA23, DA33
	91424-Z4K-801	TUBE, FUEL, 4.5X180(FKM)	1	-	1013446	DCAG
		-	1	-----	DCAG
	91434-Z5N-801	HOSE, FUEL, 4.5X130(FKM)	1	-	1004500	DCA1
		-	1	-----	DCA1

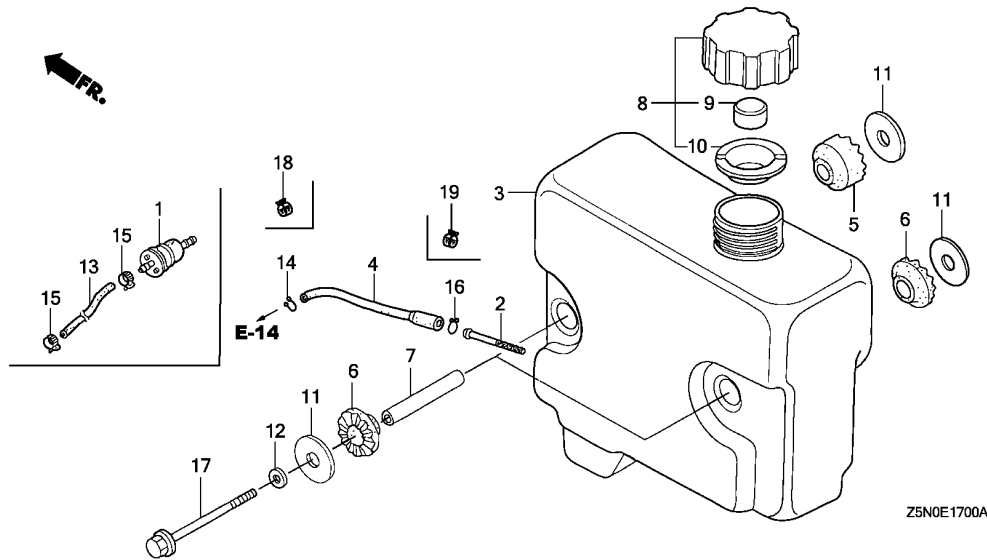

Ref. No.	Part No.	Description	Reqd. QTY		Serial No.	Parts catalogue code
			GXV 340 UT2	GXV 340 RT2		
13)	91434-Z5N-811	HOSE, FUEL, 4.5X360(FKM)	1	-	1013308	----- DA,DA2,DA23,DA33
	91434-Z5P-801	HOSE, FUEL, 4.5X230(FKM)	-	1	-----	----- DA,DA2,DA23,DA33
14	95002-02080	CLIP, TUBE (B8)	1	-	1004989	----- DCAG,DET3,DE33,DNE4,DNG4,DN4,DXE2,DX2,DX3
15	95002-40850-08	CLAMP, TUBE (D8.5)	2	2	-----	----- DA,DAS,DA2,DA23,DA33,DCA1
16	95002-70000	CLIP, TUBE (C11)	1	-	1004989	----- DET3,DE33,DNE4,DNG4,DN4,DXE2,DX2,DX3
17	95701-08095-00	BOLT, FLANGE, 8X95	2	-	-----	----- DET3,DE33,DNE4,DNG4,DN4,DXE2,DX2,DX3
18	95002-40800-08	CLAMP, TUBE (D8)	1	-	1004990	----- DCAG,DET3,DE33,DNE4,DNG4,DN4,DXE2,DX2,DX3
			-	1	-----	----- DCAG
19	95002-41050-08	CLAMP, TUBE (D10.5)	1	-	1004990	----- DET3,DE33,DNE4,DNG4,DN4,DXE2,DX2,DX3



E-19

FLYWHEEL

D 6

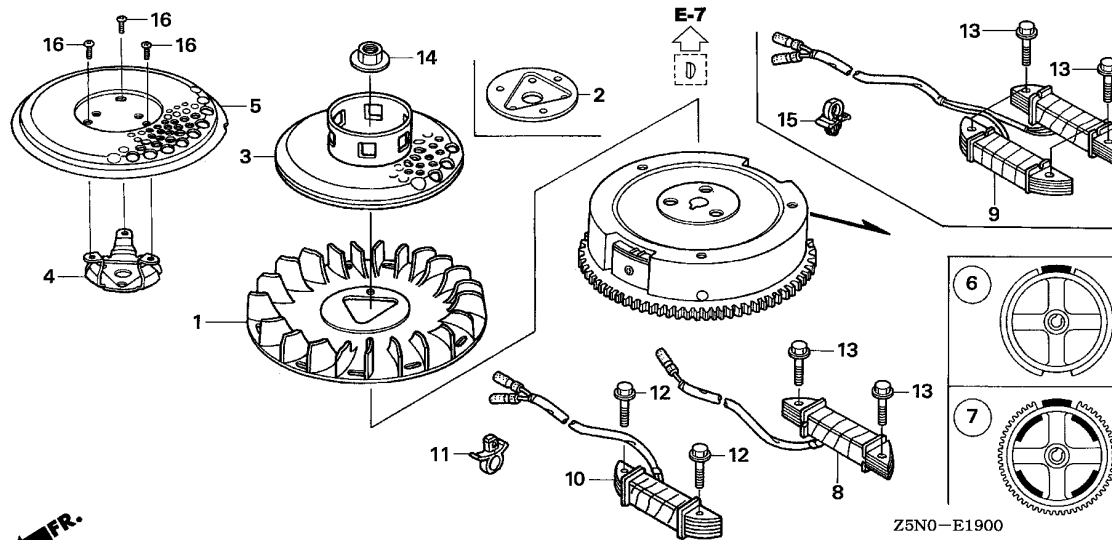

Ref. No.	L.O.N.	(Relative ref. Number) Description	F.R.T.
1	1141G7	FAN, ENGINE COOLING	0.2
3	(5)		
3	1121A9	PULLEY, RECOIL STARTER	0.2
6	(7)		
6	2161B5	FLYWHEEL	0.3
8	6141A6	COIL, LAMP	0.3
10	(9)		
10	6131C3	COIL, CHARGE	0.3

Ref. No.	Part No.	Description	Reqd. QTY		Serial No.	Parts catalogue code
			GXV 340 UT2	GXV 340 RT2		
1	19511-ZE9-010	FAN, COOLING	1	1		
2	19512-ZE2-000	PLATE, COOLING FAN SETTING	1	1		DCAG
3	28450-ZE9-004	PULLEY COMP., STARTER (SCREEN GRID)	1	1		DA, DAS, DA2, DA23, DA33, DET3, DE33, DNE4, DNG4, DN4, DXE2, DX2, DX3
4	28451-ZE9-801	HOLDER, SCREEN GRID	1	1		DCA1, DM33
5	28452-ZE8-801	GRID, SCREEN	1	1		DCA1, DM33
6	31100-ZE9-020	FLYWHEEL COMP.	1	1		DA, DA2, DA23, DA33, DNG4, DN4, DX2, DX3
7	31110-ZF5-L32	FLYWHEEL COMP. (SEL-4POLE)	1	1		DAS, DCAG, DCA1, DET3, DE33, DM33, DNE4, DXE2
8	31510-ZF5-811	COIL ASSY., LAMP (12V70W)	1	-		DXE2
9	31630-ZF5-V01	COIL ASSY., CHARGE (10A)	1	1		DCAG
10	31630-ZF5-003	COIL ASSY., CHARGE	1	1		DAS, DCA1, DET3, DE33
	31630-ZF5-801	COIL ASSY., CHARGE (1A)	1	-		DNE4, DXE2
	31630-ZE2-841	COIL ASSY., CHARGE (3A)	1	-		DM33
	31630-ZE2-842	-	1		DM33
11	46391-VM0-003	CLIP, BRAKE PIPE (A)	1	1		DAS, DCA1, DET3, DE33, DM33, DNE4, DXE2
12	90015-883-000	BOLT, FLANGE, 6X28	2	2		DAS, DCA1, DET3, DE33, DM33, DNE4, DXE2
13	90031-ZE1-000	BOLT, FLANGE, 6X32	2	-		DXE2
			4	4		DCAG
14	90201-ZE3-V00	NUT, SPECIAL, 16MM	1	-		
	90201-ZE3-790	-	1		
15	90682-735-A01	CLIP, WIRE HARNESS	1	1		DCAG
16	93500-05008-0A	SCREW, PAN, 5X8	3	3		DCA1, DM33

2

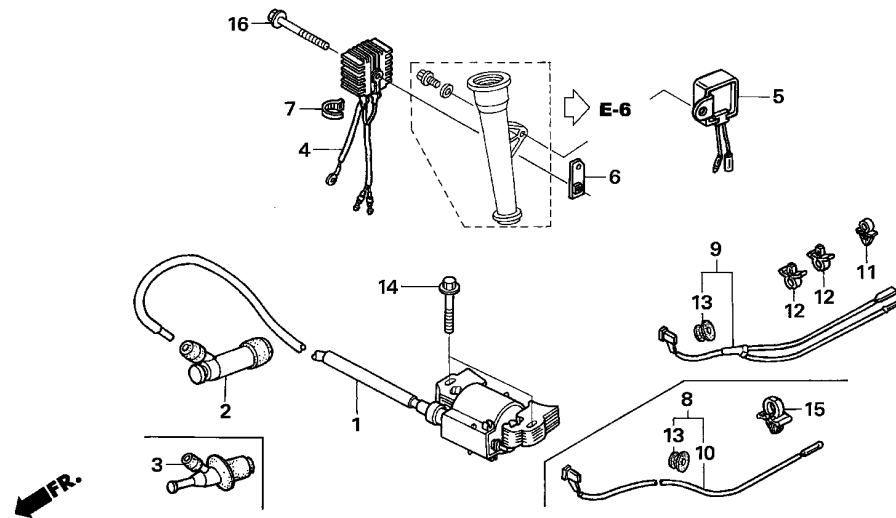

Z5N0-E2000

Ref. No.	L.O.N.	(Relative ref. Number) Description	F.R.T.
1	6141A5	COIL, IGNITION(ONE) (3)	0.3
2	6141B8	TERMINAL, HIGH TENSION (5)	0.1
4	6131B8	RECTIFIER, SILICON (9)	0.2
8	6111B3	CORD, STOP SWITCH	0.3

Ref. No.	Part No.	Description	Reqd. QTY		Serial No.	Parts catalogue code
			GXV 340 UT2	GXV 340 RT2		
1	30500-Z1E-013 30500-Z1E-023	COIL ASSY., IGNITION	1	-	1013558	
			-	1	1013559	
2	30700-ZF5-013	CAP ASSY., NOISE SUPPRESSOR	1	1		DA,DAS,DA2,DA23,DA33,DET3,DE33,DNE4,DNG4,DN4,DXE2,DX2,DX3
3	30700-Z1F-811	CAP ASSY., NOISE SUPPRESSOR	1	1		DCAG,DCA1,DM33
4	31700-ZE8-003	RECTIFIER ASSY., SILICON	1	1		DAS,DET3,DE33
5	31700-ZF5-003	RECTIFIER COMP., SILICON	1	-		DNE4,DXE2
6	31717-ZF5-V00	BRACKET, RECTIFIER	1	1		DAS,DET3,DE33
7	32161-404-610	BAND B1, WIRE	1	1		DAS,DET3,DE33,DNE4,DXE2
8	36101-ZE8-000	CORD, STOP SWITCH	1	-		DNE4,DN4,DX3
9	36101-ZE8-810	CORD, STOP SWITCH	1	1		DA,DAS,DA2,DA23,DA33,DET3,DE33,DNG4,DXE2,DX2
10	36101-ZE9-L30	CORD, STOP SWITCH	1	1		DCAG,DCA1,DM33
11	36103-ZE1-000	HOLDER, STOP SWITCH CORD	1	1		DA2,DA23,DA33,DXE2,DX2
	51125-ZOL-003	HOLDER, WIRE (FASTEX)	1	1		DA2,DA23,DA33,DXE2,DX2
12	46391-VMO-003	CLIP, BRAKE PIPE (A)	2	2		DA,DAS,DA2,DA23,DA33,DET3,DE33,DNE4,DNG4,DN4,DXE2,DX2,DX3
13	80101-166-000	GROMMET, WIRE CORD	1	1		DA,DAS,DA2,DA23,DA33,DET3,DE33,DNE4,DNG4,DN4,DXE2,DX2,DX3
14	90015-883-000	BOLT, FLANGE, 6X28	2	2		
15	91504-SLO-003	CLIP, HOOD OPEN WIRE	1	1		DCAG,DCA1,DM33
16	95701-06032-00	BOLT, FLANGE, 6X32	1	1		DAS,DET3,DE33



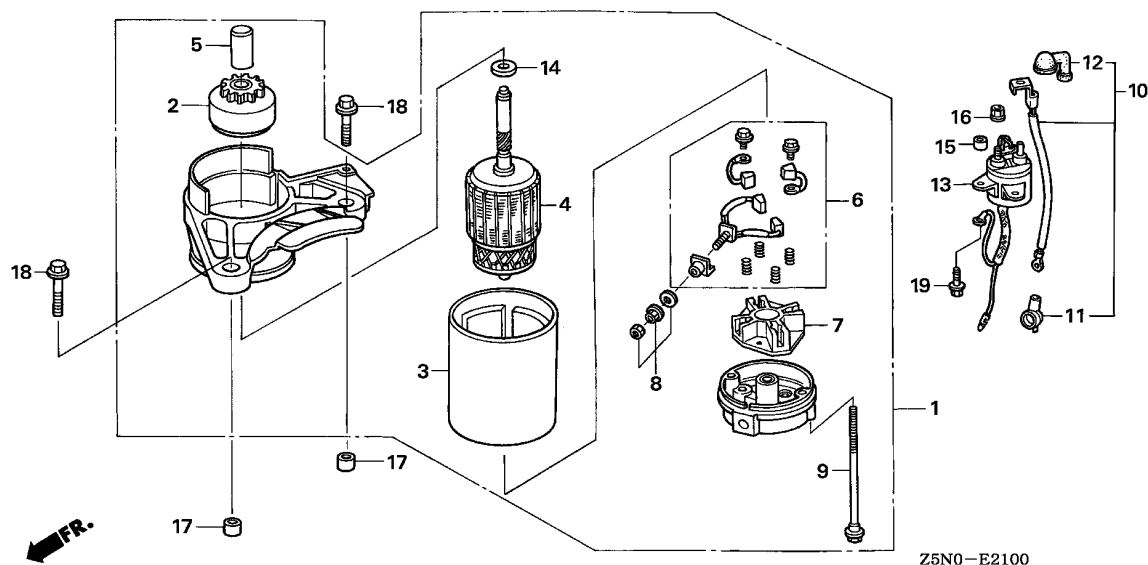

Ref. No.	L.O.N.	(Relative ref. Number) Description	F.R.T.
1	6121D5	MOTOR, STARTER	0.3
2		(5)	
2	6121B0	CLUTCH, OVERRUNNING	0.4
3	6121D1	YOKE, STARTER	0.5
4	6121A0	ARMATURE, STARTER	0.5
6		(7)	
6	6121A8	BRUSH SET, STARTER	0.4
13	6121C9	SWITCH, STARTER MAGNETIC	0.2

Ref. No.	Part No.	Description	Reqd. QTY		Serial No.	Parts catalogue code
			GXV 340 UT2	GXV 340 RT2		
1	31200-ZF5-L32	MOTOR ASSY., STARTER	1	1	-----	DAS,DCAG,DCA1,DET3,DE33,DM33,DNE4,DXE2
2	31206-ZF5-L31	DRIVE ASSY.	1	1	-----	DAS,DCAG,DCA1,DET3,DE33,DM33,DNE4,DXE2
3	31216-ZJ1-004	YOKE COMP.	1	1	-----	DAS,DCAG,DCA1,DET3,DE33,DM33,DNE4,DXE2
4	31217-ZF5-L31	ARMATURE COMP.	1	1	-----	DAS,DCAG,DCA1,DET3,DE33,DM33,DNE4,DXE2
5	31225-ZF5-L31	STOPPER SET, PINION	1	1	-----	DAS,DCAG,DCA1,DET3,DE33,DM33,DNE4,DXE2
6	31226-ZF5-L31	BRUSH SET	1	1	-----	DAS,DCAG,DCA1,DET3,DE33,DM33,DNE4,DXE2
7	31231-ZJ1-004	HOLDER COMP., BRUSH	1	1	-----	DAS,DCAG,DCA1,DET3,DE33,DM33,DNE4,DXE2
8	31237-ZJ1-004	NUT SET, TERMINAL	1	1	-----	DAS,DCAG,DCA1,DET3,DE33,DM33,DNE4,DXE2
9	31261-ZF5-L31	BOLT, THROUGH	2	2	-----	DAS,DCAG,DCA1,DET3,DE33,DM33,DNE4,DXE2
10	32402-ZF5-V00	CORD, MAGNET SWITCH	1	1	-----	DAS,DCAG,DCA1,DET3,DE33,DNE4,DXE2
11	32411-ZV4-811	COVER, STARTER TERMINAL	1	1	-----	DAS,DCAG,DCA1,DET3,DE33,DNE4,DXE2
12	32412-ZV4-811	COVER, MAGNETIC SWITCH	1	1	-----	DAS,DCAG,DCA1,DET3,DE33,DNE4,DXE2
13	35850-ZF5-V01	SWITCH ASSY., STARTER MAGNETIC	1	1	-----	DAS,DCAG,DCA1,DET3,DE33,DNE4,DXE2
14	90407-ZF5-L31	WASHER, THRUST	1	1	-----	DAS,DCAG,DCA1,DET3,DE33,DM33,DNE4,DXE2
15	91504-ZF5-V00	COLLAR, DISTANCE	2	-	1015818	DAS,DCAG,DCA1,DET3,DE33,DNE4,DXE2
	91503-ZY1-300	COLLAR, 6.5X11X10	2	-	1015819	DAS,DCAG,DCA1,DET3,DE33,DNE4,DXE2
			-	2	-----	DAS,DCAG,DCA1
16	94070-06080	NUT-WASHER, 6MM	2	2	-----	DAS,DCAG,DCA1,DET3,DE33,DNE4,DXE2
17	94301-10120	DOWEL PIN, 10X12	2	2	-----	DAS,DCAG,DCA1,DET3,DE33,DM33,DNE4,DXE2
18	95701-08035-00	BOLT, FLANGE, 8X35	2	2	-----	DAS,DCAG,DCA1,DET3,DE33,DM33,DNE4,DXE2
19	96001-06025-00	BOLT, FLANGE, 6X25	2	2	-----	DAS,DCAG,DCA1,DET3,DE33,DNE4,DXE2

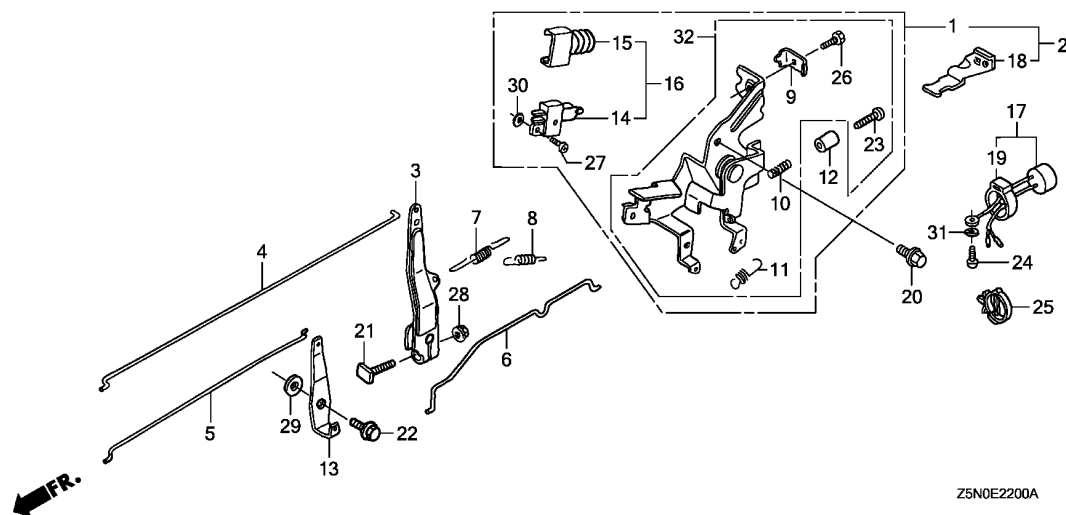

Z5N0E2200A

Ref. No.	L.O.N.	(Relative ref. Number) Description	F.R.T.
1		(2)	
1	1161A5	CONTROL, THROTTLE/GOVERNOR ...	0.2
3	1161A0	ARM, GOVERNOR	0.2
4	1161B1	ROD, GOVERNOR	0.2
5	8101R5	ROD, GOVERNOR CHOKE CONTROL ..	0.2
6	1161B2	ROD, JOINT	0.2
7	1161C5	SPRING, GOVERNOR	0.1
8	1161B9	SPRING, GOVERNOR PRIMARY	0.1
16		(14)	
	6151D9	SWITCH, ENGINE STOP	0.1
	6211C3	BUZZER, WARNING	0.2

Ref. No.	Part No.	Description	Reqd. QTY		Serial No.	Parts catalogue code
			GXV 340 UT2	GXV 340 RT2		
1	16500-ZF5-010	CONTROL ASSY.	1	1	-----	DA,DET3,DE33,DX3
	16500-ZF5-821	1	-	-----	DNE4,DNG4,DN4
2	16500-ZF5-800	CONTROL ASSY.	1	1	-----	DA2,DA23,DA33,DXE2,DX2
3	16551-ZF5-000	ARM, GOVERNOR	1	1	-----	DA,DAS,DA2,DA23,DA33,DET3,DE33,DNE4,DNG4,DN4,DXE2,DX2,DX3
4	16555-ZE9-000	ROD, GOVERNOR	1	1	-----	DA,DAS,DA2,DA23,DA33,DET3,DE33,DNE4,DNG4,DN4,DXE2,DX2,DX3
5	16556-ZE9-000	ROD, CHOKE	1	1	-----	DA,DAS,DA2,DA23,DA33,DET3,DE33,DNE4,DNG4,DN4,DXE2,DX2,DX3
6	16557-ZE8-810	ROD, JOINT	1	1	-----	DA,DAS,DA2,DA23,DA33,DET3,DE33,DNE4,DNG4,DN4,DXE2,DX2,DX3
7	16561-ZF5-000	SPRING, GOVERNOR	1	1	-----	DA,DAS,DA2,DA23,DA33,DET3,DE33,DNE4,DNG4,DN4,DXE2,DX2,DX3
8	16563-ZE8-000	SPRING, GOVERNOR PRIMARY	1	1	-----	DA,DAS,DA2,DA23,DA33,DET3,DE33,DNE4,DNG4,DN4,DXE2,DX2,DX3
9	16576-891-000	HOLDER, CABLE	1	1	-----	DA,DAS,DA2,DA23,DA33,DET3,DE33,DNE4,DNG4,DN4,DXE2,DX2,DX3
10	16584-883-300	SPRING, CONTROL ADJUSTING	1	1	-----	DA,DAS,DA2,DA23,DA33,DET3,DE33,DNE4,DNG4,DN4,DXE2,DX2,DX3
11	16592-732-700	SPRING, CABLE RETURN	1	1	-----	DA,DAS,DA2,DA23,DA33,DET3,DE33,DNE4,DNG4,DN4,DXE2,DX2,DX3
12	16599-ZG1-M10	COLLAR, STOPPER	1	-	-----	DNE4,DNG4,DN4
13	16619-ZF5-000	LEVER, CHOKE JOINT	1	1	-----	DA,DAS,DA2,DA23,DA33,DET3,DE33,DNE4,DNG4,DN4,DXE2,DX2,DX3
14	35330-ZG1-751	SWITCH ASSY., ENGINE	1	1	-----	DA,DA2,DA23,DA33,DET3,DE33,DNE4,DNG4,DN4,DXE2,DX2,DX3
15	35336-750-003	COVER, SWITCH	1	1	-----	DA,DA2,DA23,DA33,DET3,DE33,DNE4,DNG4,DN4,DXE2,DX2,DX3
16	36100-ZE8-003	SWITCH ASSY., ENGINE STOP ...	1	1	-----	DA,DA2,DA23,DA33,DET3,DE33,DNE4,DNG4,DN4,DXE2,DX2,DX3
17	38400-ZE8-003	BUZZER ASSY.	1	1	-----	DA2,DA23,DA33,DXE2,DX2
18	38401-ZF5-800	STAY, BUZZER	1	1	-----	DA2,DA23,DA33,DXE2,DX2
19	38402-GC1-000	SUSPENSION, AUDIBLE PILOT ...	1	1	-----	DA2,DA23,DA33,DXE2,DX2
20	90013-883-000	BOLT, FLANGE, 6X12(CT200) ...	1	1	-----	DA,DAS,DA2,DA23,DA33,DET3,DE33,DNE4,DNG4,DN4,DXE2,DX2,DX3
21	90015-ZE5-010	BOLT, GOVERNOR ARM	1	1	-----	DA,DAS,DA2,DA23,DA33,DET3,DE33,DNE4,DNG4,DN4,DXE2,DX2,DX3
22	90015-ZE8-000	BOLT, FLANGE, 6MM	1	1	-----	DA,DAS,DA2,DA23,DA33,DET3,DE33,DNE4,DNG4,DN4,DXE2,DX2,DX3
23	90016-ZF5-W40	SCREW, RECESSED, 5X20	1	-	-----	DNE4,DNG4,DN4
	93500-05020-0A	SCREW, PAN, 5X20	1	1	-----	DA,DAS,DA2,DA23,DA33,DET3,DE33,DXE2,DX2,DX3



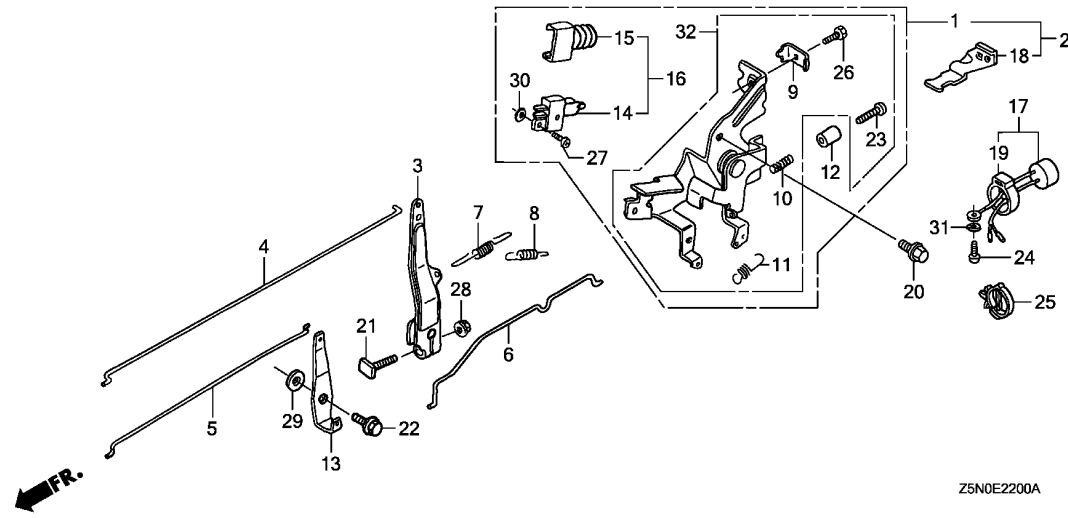

Ref. No.	Part No.	Description	Reqd. QTY		Serial No.	Parts catalogue code
			GXV 340 UT2	GXV 340 RT2		
24	90050-ZE1-000	SCREW, TAPPING, 5X8	1	1	-----	DA2,DA23,DA33,DXE2,DX2
25	90684-ZA0-601	CLIP, HARNESS	1	1	-----	DA2,DA23,DA33,DXE2,DX2
26	92301-05014-1A	BOLT, RECESSED, 5X14	1	1	-----	DA,DAS,DET3,DE33,DNE4,DNG4,DN4,DX3
	92301-05016-0A	BOLT, RECESSED, 5X16	1	1	-----	DA2,DA23,DA33,DXE2,DX2
27	93500-04014-0A	SCREW, PAN, 4X14	1	1	-----	DA,DA2,DA23,DA33,DET3,DE33,DNE4,DNG4,DN4,DXE2,DX2,DX3
28	94050-06000	NUT, FLANGE, 6MM	1	1	-----	DA,DAS,DA2,DA23,DA33,DET3,DE33,DNE4,DNG4,DN4,DXE2,DX2,DX3
29	94101-06800	WASHER, PLAIN, 6MM	1	1	-----	DA,DAS,DA2,DA23,DA33,DET3,DE33,DNE4,DNG4,DN4,DXE2,DX2,DX3
30	94111-04000	WASHER, SPRING, 4MM	1	1	-----	DA,DA2,DA23,DA33,DET3,DE33,DNE4,DNG4,DN4,DXE2,DX2,DX3
31	94111-05000	WASHER, SPRING, 5MM	1	1	-----	DA2,DA23,DA33,DXE2,DX2
32	16500-ZF5-U11	CONTROL ASSY. (AYP)	1	1	-----	DAS

E-22-1

CONTROL(2)

D11

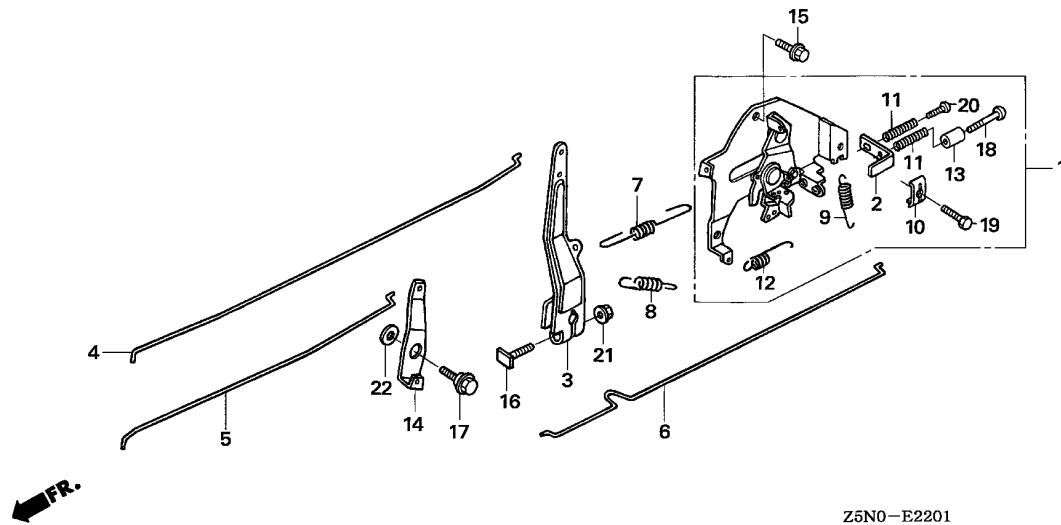

Ref. No.	L.O.N.	(Relative ref. Number) Description	F.R.T.
1	1161A5	CONTROL, THROTTLE/GOVERNOR ...	0.2
3	1161A0	ARM, GOVERNOR	0.2
4	1161B1	ROD, GOVERNOR	0.2
5	8101R5	ROD, GOVERNOR CHOKE CONTROL ..	0.2
6	1161B2	ROD, JOINT	0.2
7	1161C5	SPRING, GOVERNOR	0.1

Ref. No.	Part No.	Description	Reqd. QTY		Serial No.	Parts catalogue code
			GXV 340 UT2	GXV 340 RT2		
1	16500-ZF5-U20	CONTROL ASSY.	1	1	-----	DCAG,DCA1
	16500-ZE9-L30	1	1	-----	DM33
2	16539-ZF5-L40	PLATE, SCREW ADJUST GUARD ...	1	1	-----	DCAG,DCA1
3	16551-ZF5-000	ARM, GOVERNOR	1	1	-----	DCAG,DCA1,DM33
4	16555-ZE9-000	ROD, GOVERNOR	1	1	-----	DCAG,DCA1,DM33
5	16556-ZE9-000	ROD, CHOKE	1	1	-----	DCAG,DCA1,DM33
6	16557-ZE8-000	ROD, JOINT	1	1	-----	DCAG,DCA1,DM33
7	16561-ZF5-000	SPRING, GOVERNOR	1	1	-----	DCAG,DCA1,DM33
8	16563-ZE8-000	SPRING, GOVERNOR PRIMARY	1	1	-----	DCAG,DM33
9	16574-ZF5-L00	SPRING, LEVER	1	1	-----	DCAG,DCA1,DM33
10	16576-891-000	HOLDER, CABLE	1	1	-----	DCAG,DCA1
11	16584-883-300	SPRING, CONTROL ADJUSTING ...	2	2	-----	DCAG,DCA1,DM33
12	16592-732-700	SPRING, CABLE RETURN	1	1	-----	DCAG,DCA1,DM33
13	16599-ZG1-M10	COLLAR, STOPPER	1	1	-----	DCAG,DCA1
14	16619-ZF5-000	LEVER, CHOKE JOINT	1	1	-----	DCAG,DCA1,DM33
15	90013-883-000	BOLT, FLANGE, 6X12(CT200) ...	1	1	-----	DCAG,DCA1,DM33
16	90015-ZE5-010	BOLT, GOVERNOR ARM	1	1	-----	DCAG,DCA1,DM33
17	90015-ZE8-000	BOLT, FLANGE, 6MM	1	1	-----	DCAG,DCA1,DM33
18	90016-ZG1-M10	SCREW, RECESSED, 5X35	1	1	-----	DCAG,DCA1
	90016-ZG1-700	BOLT, RECESSED, 5X34	1	1	-----	DM33
19	92301-05016-0A	BOLT, RECESSED, 5X16	1	1	-----	DCAG,DCA1
20	92301-05022-0A	BOLT, RECESSED, 5X22	1	1	-----	DCAG,DCA1
	92301-05020-0A	BOLT, RECESSED, 5X20	1	1	-----	DM33
21	94050-06000	NUT, FLANGE, 6MM	1	1	-----	DCAG,DCA1,DM33
22	94101-06800	WASHER, PLAIN, 6MM	1	1	-----	DCAG,DCA1,DM33

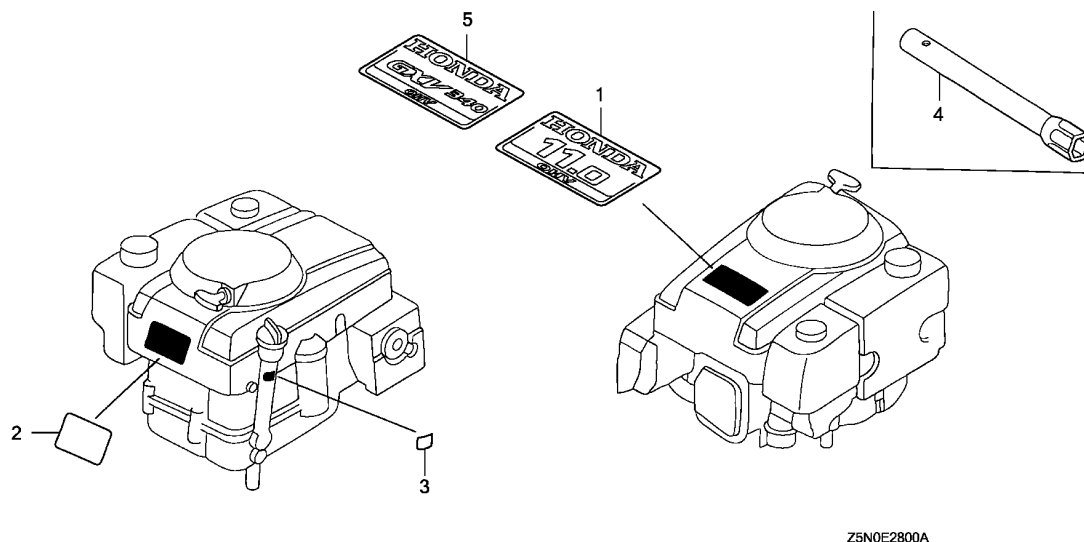

Ref. No. L.O.N. (Relative ref. Number) Description F.R.T.

NO INFORMATION

Ref. No.	Part No.	Description	Reqd. QTY		Serial No.	Parts catalogue code
			GXV 340 UT2	GXV 340 RT2		
1	87101-ZE9-V01	EMBLEM, TOP COVER (11.0)	1	-	1015818	DA,DAS,DA2,DA23,DA33,DCAG,DCA1,DET3,DE33,DNE4,DNG4,DN4,DXE2,DX2,DX3
2	87516-Z4H-000	MARK, OPERATOR CAUTION (ENGLISH)(MADE IN THAI)	1	1		
	87516-Z4H-810	MARK, OPERATOR CAUTION (PICTOGRAPH)(MADE IN THAI)	(1)	(1)		
3	87601-ZE9-U40	MARK, TYPE (DCA1)	1	1	-----	DCA1
	87601-ZF5-T10	MARK, TYPE (DAS)	1	1	-----	DAS
	87601-ZF5-V50	MARK, TYPE (DX2)	1	-	-----	DX2
	87601-ZF5-V60	MARK, TYPE (DXE2)	1	-	-----	DXE2
	87601-ZF5-V70	MARK, TYPE (DA2)	1	1	-----	DA2
	87601-ZF5-W00	MARK, TYPE (DA33)	1	1	-----	DA33
	87601-ZF5-W10	MARK, TYPE (DA23)	1	1	-----	DA23
	87601-ZF5-W20	MARK, TYPE (DE33)	1	-	-----	DE33
	87601-ZF5-W30	MARK, TYPE (DET3)	1	-	-----	DET3
	87601-ZF5-W40	MARK, TYPE (DN4)	1	-	-----	DN4
	87601-ZF5-W50	MARK, TYPE (DNE4)	1	-	-----	DNE4
	87601-ZF5-820	MARK, TYPE (DA)	1	1	-----	DA
	87601-ZF5-850	MARK, TYPE (DX3)	1	-	-----	DX3
	87601-ZF5-860	MARK, TYPE (DNG4)	1	-	-----	DNG4
	87601-Z1F-U50	MARK, TYPE (DCAG)	1	1	-----	DCAG
	87601-Z5N-800	MARK, TYPE (DM33)	1	1	-----	DM33
4	99004-21002	WRENCH, BOX (P21)	1	1	-----	DA,DAS,DA2,DA23,DA33,DCA1,DET3,DE33,DXE2,DX2,DX3
5	87101-ZE9-V02	EMBLEM, TOP COVER (GXV340) ..	1	-	1015819	DA,DAS,DA2,DA23,DA33,DCAG,DCA1,DET3,DE33,DNE4,DNG4,DN4,DXE2,DX2,DX3
			-	1	-----	DA,DAS,DA2,DA23,DA33,DCAG,DCA1

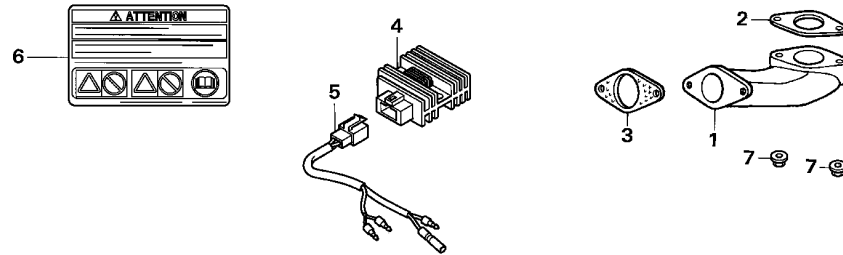

Z5N0-E4000

Ref. L.O.N. (Relative ref. Number) F.R.T.
No. Description

NO INFORMATION

Ref. No.	Part No.	Description	Reqd. QTY		Serial No.	Parts catalogue code
			GXV 340 UT2	GXV 340 RT2		
1	18331-ZF5-000	PIPE, EX.	1	1	-----	DCA1
2	18333-ZE3-800	GASKET, EX. PIPE	1	1	-----	DCAG
3	18382-ZE9-800	GASKET, EX. PIPE	2	2	-----	DCA1
4	31600-ZE2-861	RECTIFIER ASSY., REGULATOR	1	1	-----	DCA1
		(10A)				
5	32110-ZB5-630	HARNESS ASSY., SUB WIRE	1	1	-----	DCAG, DCA1
						DCAG
6	87516-Z4H-800	MARK, OPERATOR CAUTION (FRENCH)(MADE IN THAI)	1	1	-----	
7	94050-08000	NUT, FLANGE, 8MM	2	2	-----	DCA1



EOP-1

GASKET KIT

D14

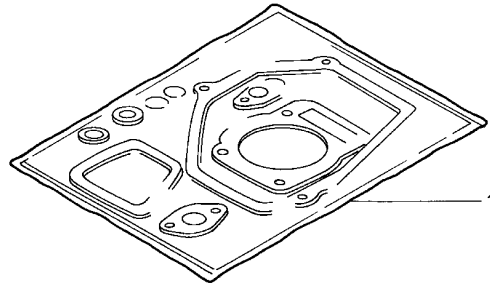

HENG-X0003

Ref. No.	L.O.N.	(Relative ref. Number) Description	F.R.T.
----------	--------	---------------------------------------	--------

NO INFORMATION

Ref. No.	Part No.	Description	Reqd. QTY		Serial No.	Parts catalogue code
			GXV 340 UT2	GXV 340 RT2		
1	06111-ZE9-V01	GASKET KIT	1	1	-----	DA,DNE4,DNG4,DN4,DXE2,DX2

2

PART NO. INDEX

E 2

Part Number	Address	Page	Ref.	Part Number	Address	Page	Ref.	Part Number	Address	Page	Ref.	Part Number	Address	Page	Ref.
35000				90000				91000				94109-20000 C4 20 42			
35330-ZG1-751	D9	41	14	90001-ZE8-000	C8	24	5	91001-ZF5-003	C2	18	12	94111-04000	C5	21	55
35336-750-003	D9	41	15	90004-ZE2-W01	C12	28	11	91201-Z1C-003	C2	18	13	94111-05000	D10	42	30
35410-ZF5-013	C4	20	25	90006-ZF5-V00	C13	29	8		C4	20	33	94251-10000	D10	42	31
35419-ZF5-000	C4	20	26	90012-ZE0-010	C9	25	16	91203-952-771	C2	18	14	94301-10120	C2	18	15
35850-ZF5-V01	D8	40	13	90013-883-000	C1	17	10	91301-ZE9-003	C4	20	34	94301-12200	D8	40	17
					C2	18	10	91302-ZE9-003	C4	20	35		C1	17	15
36000					C4	20	27	91302-ZL8-003	C4	20	36	95000			
36100-ZE8-003	D9	41	16		C13	29	9	91303-HA0-004	C4	20	37	95001-45130-20	D4	36	13
36101-ZE8-000	D7	39	8		D9	41	20	91424-Z4K-801	D4	36	13	95001-45180-30	D1	33	24
36101-ZE8-810	D7	39	9	90014-ZE6-000	D11	43	15	91434-Z5N-801	D4	36	13	95001-45180-40	D4	36	13
36101-ZE9-L30	D7	39	10		C4	20	28	91434-Z5N-811	D5	37	13	95001-45230-50	D4	36	13
36103-ZE1-000	D7	39	11		D2	34	5	91434-Z5P-801	D5	37	13	95001-45360-20	D4	36	13
				90014-ZE8-000	C1	17	11	91501-ZF5-000	C4	20	38	95002-02080	D4	30	23
38000				90015-883-000	D6	38	12	91501-ZF5-V00	C13	29	12		D1	33	25
					D7	39	14	91502-ZF5-V00	D2	34	7		D5	37	14
				90015-ZE5-010	D9	41	21	91503-ZF5-V00	D2	34	8	95002-40800-08	D5	37	18
38400-ZE8-003	D9	41	17		D11	43	16	91503-ZY1-300	D8	40	15	95002-40850-08	D5	37	15
38401-ZF5-800	D9	41	18	90015-ZE8-000	D9	41	22	91504-SL0-003	D7	39	15	95002-41050-08	D5	37	19
38402-GC1-000	D9	41	19		D11	43	17	91504-ZF5-V00	D8	40	15	95002-70000	D5	37	16
				90016-ZE8-000	D2	34	5	92000				95701-06010-00	C13	29	14
46000				90016-ZF5-W40	D9	41	23					95701-06012-00	C1	17	16
				90016-ZG1-700	D11	43	18	92301-05014-1A	D10	42	26		C4	20	43
46391-VM0-003	D6	38	11	90016-ZG1-M10	D11	43	18	92301-05016-0A	D10	42	26	95701-06016-00	C4	20	44
	D7	39	12	90018-PN3-000	C4	20	29		D11	43	19	95701-06025-00	C4	20	45
				90029-888-000	C13	29	10	92301-05020-0A	D11	43	20	95701-06032-00	D7	39	16
51000				90031-883-000	D3	35	10	92301-05022-0A	D11	43	20	95701-08014-00	D3	35	18
				90031-ZE1-000	D6	38	13	92800-20000	C4	20	39	95701-08020-08	C13	29	15
51125-Z0L-003	D7	39	11	90031-ZF5-L00	C5	21	50	92900-08022-0B	C1	17	14	95701-08035-00	D8	40	18
				90042-ZE8-000	C1	17	12	92900-08032-0B	C1	17	14	95701-08040-08	C4	20	46
80000				90042-ZE8-700	C1	17	12	92900-08060-1B	D3	35	13	95701-08060-08	C5	21	47
				90050-ZE1-000	D3	35	11	92900-08070-1B	D3	35	14	95701-08095-00	D5	37	17
80101-166-000	D7	39	13		D10	42	24					95701-10080-00	C1	17	17
				90055-ZE1-000	D3	35	12	93000				96000			
87000				90121-952-000	C4	20	30					96001-06025-00	D8	40	19
				90131-ZE1-000	C5	21	51	93500-03006-1H	C14	30	22	96100-62073-00	C2	18	16
87101-ZE9-V01	D12	44	1	90201-ZE3-790	D6	38	14		C16	32	23		C5	21	48
87101-ZE9-V02	D12	44	5	90201-ZE3-V00	D6	38	14	93500-04014-0A	D10	42	27	98000			
87516-Z4H-000	D12	44	2	90206-ZE1-000	C9	25	17	93500-05008-0A	D6	38	16	98079-55876	C1	17	18
87516-Z4H-800	D13	45	6	90320-747-000	C13	29	11	93500-05020-0A	D9	41	23	99000			
87516-Z4H-810	D12	44	2	90325-044-000	D2	34	6	93500-06006-0A	D3	35	15	99004-21002	D12	44	4
87601-Z1F-U50	D12	44	3	90406-VM6-000	C2	18	11					99101-ZH8-0880	C14	30	24
87601-Z5N-800	D12	44	3	90407-ZF5-L31	D8	40	14	94000				99101-ZH8-0900	C15	31	24
87601-ZE9-U40	D12	44	3	90417-HA0-000	C6	22	4						D1	33	26
87601-ZF5-820	D12	44	3	90441-ZE2-010	C1	17	13	94050-06000	C12	28	12		C15	31	24
87601-ZF5-850	D12	44	3	90455-896-700	D4	36	11		C13	29	13	99204-ZE0-0380	C15	31	25
87601-ZF5-860	D12	44	3	90471-SB0-000	D4	36	12		D2	34	9		D1	33	27
87601-ZF5-T10	D12	44	3	90601-ZE1-000	C5	21	52		D10	42	28		D1	33	26
87601-ZF5-V50	D12	44	3	90601-ZE3-000	C8	24	6	94050-08000	D11	43	21		D1	33	26
87601-ZF5-V60	D12	44	3	90601-ZF5-L00	C5	21	53		D13	45	7		C15	31	24
87601-ZF5-V70	D12	44	3	90602-ZE1-000	C4	20	31	94070-06080	D8	40	16		D1	33	26
87601-ZF5-W00	D12	44	3	90634-ZL8-H00	D2	34	11	94101-06000	D3	35	17		D1	33	26
87601-ZF5-W10	D12	44	3	90682-735-A01	D6	38	15	94101-06800	C4	20	40		C15	31	25
87601-ZF5-W20	D12	44	3	90684-ZA0-601	D10	42	25		D10	42	29		D1	33	27
87601-ZF5-W30	D12	44	3	90701-HC4-000	C4	20	32		D11	43	22				
87601-ZF5-W40	D12	44	3	90741-ZE2-000	C6	22	5	94103-06700	C4	20	41				
87601-ZF5-W50	D12	44	3												

PART NAME INDEX

F 1

Part name	Address	Page	Ref.	Part name	Address	Page	Ref.	Part name	Address	Page	Ref.	
[A]												
ARMATURE COMP.	D8	40	4	BOLT, RECESSED, 5X22	D11	43	20	COLLAR, OIL FILTER SETTING.....	C4	20	38	
ARM, GOVERNOR	D9	41	3	BOLT, RECESSED, 5X34	D11	43	18	COLLAR, SETTING.....	C14	30	12	
	D11	43	3	BOLT, STUD, 8X131.5	C1	17	12		C16	32	12	
ARM, VALVE ROCKER	C9	25	4	BOLT, STUD, 8X138.5	C1	17	12	COLLAR, STOPPER.....	D9	41	12	
ARRESTER, SPARK	D3	35	8	BOLT, STUD, 8X22	C1	17	14		D11	43	13	
				BOLT, STUD, 8X32	C1	17	14	COLLAR, TANK SETTING.....	D4	36	7	
				BOLT, STUD, 8X60	D3	35	13	CONTROL ASSY.....	D9	41	1	
				BOLT, STUD, 8X70	D3	35	14				2	
				BOLT, THROUGH	D8	40	9		D10	42	32	
				BRACKET, FAN COVER	C13	29	4		D11	43	1	
				BRACKET, L. FAN COVER	C13	29	5	CORD, MAGNET SWITCH.....	D8	40	10	
				BRACKET, RECTIFIER	D7	39	6	CORD, STOP SWITCH.....	D7	39	8	
				BRACKET, R. FAN COVER	C13	29	3				9	
				BRUSH SET	D8	40	6				10	
				BZZER ASSY.	D9	41	17	COVER COMP., FAN.....	C13	29	1	
				[C]				COVER, AIR CLEANER	D2	34	3	
				CAMSHAFT ASSY.	C9	25	2	COVER, HEAD.....	C1	17	6	
				CAP ASSY., FUEL TANK	D4	36	8	COVER, MAGNETIC SWITCH				
				CAP ASSY., NOISE SUPPRESSOR ...	D7	39	2		TERMINAL	D8	40	12
								COVER, OIL PUMP.....	C3	19	3	
				CAP ASSY., OIL FILLER	C3	19	16	COVER, SCREEN GRID	C13	29	7	
				CAP, BREATHER CHAMBER	C2	18	4	COVER, STARTER TERMINAL.....	D8	40	11	
				CAP, CHOKE DUST	C14	30	10	COVER, SWITCH.....	D9	41	15	
					C16	32	10	COVER, UNDER.....	C1	17	8	
				CAP, MUFFLER	D3	35	5	CRANKSHAFT COMP.....	C6	22	1	
				CAP, SEALING	D2	34	11	[D]				
				CARBURETOR ASSY.	C14	30	8	DOWEL PIN, 10X12.....	D8	40	17	
					C16	32	8	DOWEL PIN, 12X20.....	C1	17	15	
				CARTRIDGE, OIL FILTER	C3	19	12	DOWEL PIN, 8X12.....	C4	20	32	
				CASE COMP., RECOIL STARTER ...	C12	28	2	DRIVE ASSY.....	D8	40	2	
				CHAMBER SET, FLOAT	C14	30	4	[E]				
					C16	32	4	ELBOW COMP., AIR CLEANER.....	D2	34	4	
				CLAMP, TUBE	D5	37	15	ELEMENT COMP., AIR CLEANER....	D2	34	1	
								ELEMENT, AIR CLEANER.....	D2	34	1	
				CLIP, BRAKE PIPE	D6	38	11	EMBLEM, TOP COVER.....	D12	44	1	
					D7	39	12	EXTENSION, OIL FILLER.....	C3	19	18	
				CLIP, GOVERNOR HOLDER	C4	20	31	[F]				
				CLIP, HARNESS	D10	42	25	FAN, COOLING.....	D6	38	1	
				CLIP, HOOD OPEN WIRE	D7	39	15	FILTER, OUTER.....	D2	34	2	
				CLIP, PISTON PIN, 20MM	C8	24	6	FLOAT SET.....	C14	30	3	
				CLIP, TUBE	C14	30	23		C16	32	3	
					D1	33	25	FLYWHEEL COMP.....	D6	38	6	
				CLIP, VALVE GUIDE	C1	17	4				7	
				CLIP, WIRE HARNESS	D6	38	15	[G]				
				COIL ASSY., CHARGE	D6	38	9	GASKET KIT.....	D14	46	1	
								GASKET SET.....	C14	30	1	
				COIL ASSY., IGNITION	D7	39	1		C16	32	1	
				COIL ASSY., LAMP	D6	38	8	GASKET, CYLINDER HEAD.....	C1	17	5	
				COLLAR, 6.5X11X10	D8	40	15	GASKET, EX. PIPE.....	D3	35	7	
				COLLAR, AIR CLEANER	D2	34	7				9	
				COLLAR, DISTANCE	D8	40	15					
				COLLAR, EXTENSION	C4	20	24					
				COLLAR, FAN COVER	C13	29	12					

PART NAME INDEX

F 2

Part name	Address	Page	Ref.	Part name	Address	Page	Ref.	Part name	Address	Page	Ref.
GASKET, EX. PIPE	D13	45	2	MARK, OPERATOR CAUTION	D13	45	6	PLATE, COOLING FAN SETTING.....	D6	38	2
			3	MARK, TYPE	D12	44	3	PLATE, LEVER SETTING.....	C14	30	19
GOVERNOR ASSY.	C3	19	19	MOTOR ASSY., STARTER	D8	40	1		C16	32	19
GRID, SCREEN	D6	38	5	MUFFLER COMP.	D3	35	1	PLATE, OIL FILTER.....	C3	19	7
GRIP, STARTER	C12	28	9								8
GROMMET, WIRE CORD	D7	39	13	[N]				PLATE, OIL STOPPER.....	C3	19	11
GUIDE, AIR	C16	32	22	NOZZLE, MAIN	C14	30	11	PLATE, ONE-WAY VALVE.....	C2	18	7
GUIDE, EX. VALVE	C1	17	3		C16	32	11	PLATE, SCREW ADJUST GUARD.....	D11	43	2
GUIDE, IN. VALVE	C1	17	2	NUT-WASHER, 6MM	D8	40	16	PLATE, SIDE.....	C13	29	2
GUIDE, PUSH ROD	C9	25	15	NUT SET, TERMINAL	D8	40	8	PLUG, SPARK.....	C1	17	18
				NUT, FLANGE, 6MM	C12	28	12	PROTECTOR, MUFFLER.....	D3	35	4
[H]					C13	29	13	PROTECTOR, SWITCH.....	C4	20	26
HARNESS ASSY., SUB WIRE	D13	45	5		D2	34	9	PULLEY COMP., STARTER.....	D6	38	3
HEAD COMP., CYLINDER	C1	17	1		D10	42	28	PULLEY, RECOIL STARTER.....	C12	28	3
HOLDER COMP., BRUSH	D8	40	7		D11	43	21				
HOLDER, CABLE	D9	41	9	NUT, FLANGE, 8MM	D3	35	16	[R]			
	D11	43	10		D13	45	7	RATCHET, STARTER.....	C12	28	4
HOLDER, GOVERNOR WEIGHT	C3	19	21	NUT, PIVOT ADJUSTING	C9	25	17	RECTIFIER ASSY., REGULATOR.....	D13	45	4
HOLDER, OIL FILTER	C4	20	29	NUT, SPECIAL, 16MM	D6	38	14	RECTIFIER ASSY., SILICON.....	D7	39	4
HOLDER, SCREEN GRID	D6	38	4	NUT, SPRING, 6MM	C13	29	11	RECTIFIER COMP., SILICON.....	D7	39	5
HOLDER, STOP SWITCH CORD	D7	39	11	NUT, TOOL BOX SETTING.....	D2	34	6	RETAINER, EX. VALVE SPRING.....	C9	25	12
HOLDER, WIRE	D7	39	11					RETAINER, IN. VALVE SPRING.....	C9	25	11
HOSE, FUEL, 4.5X130	D4	36	13	[O]				RETAINER, SPRING.....	C12	28	8
HOSE, FUEL, 4.5X230	D4	36	13	OIL SEAL, 35X52X8	C2	18	13	RING SET, PISTON.....	C7	23	1
	D5	37	13		C4	20	33	ROD ASSY., CONNECTING.....	C8	24	4
HOSE, FUEL, 4.5X360	D4	36	13	OIL SEAL, 8X14X5	C2	18	14	ROD, CHOKE.....	D9	41	5
	D5	37	13	O-RING, 11X1.9	C4	20	37		D11	43	5
				O-RING, 11.8X2.4	C4	20	35	ROD, GOVERNOR.....	D9	41	4
[I]				O-RING, 22.5X2.2	C4	20	34		D11	43	4
INSULATOR, CARBURETOR	C14	30	14	O-RING, PUMP COVER	C3	19	4	ROD, JOINT.....	D9	41	6
	C16	32	13						D11	43	6
			14	[P]				ROD, PUSH.....	C9	25	3
				PACKING, BREATHER CAP	C2	18	6	ROPE, RECOIL STARTER.....	C12	28	10
				PACKING, CARBURETOR	C14	30	16	ROTATOR, VALVE.....	C9	25	14
					C16	32	16	ROTOR COMP., INNER.....	C3	19	5
JET SET, PILOT,	C15	31	25	PACKING, FUEL CAP	D4	36	10	ROTOR, OIL PUMP OUTER.....	C3	19	6
	D1	33	27	PACKING, FUEL COCK	C14	30	21	RUBBER B, TANK MOUNTING.....	D4	36	5
JET, MAIN,	C14	30	24		C16	32	21		C3	19	9
	C15	31	24	PACKING, HEAD COVER	C1	17	7	[S]			
	D1	33	26	PACKING, INSULATOR	C14	30	17	SCREEN, OIL FILTER.....	C3	19	15
JOINT, OIL DRAIN	C5	21	49		C16	32	17	SCREW SET.....	C14	30	7
				PACKING, OIL FILLER CAP	C3	19	17		C16	32	7
[K]				PACKING, OIL PAN	C2	18	1	SCREW SET, DRAIN.....	C14	30	6
KEY, SPECIAL WOODRUFF, 25X18 ..	C6	22	5	PAN ASSY., OIL	C3	19	1		C16	32	6
								SCREW SET, PILOT.....	C14	30	5
[L]									C16	32	5
LEVER, CHOKE JOINT	D9	41	13	PIN, GOVERNOR WEIGHT	C3	19	22	SCREW, CENTER.....	C12	28	11
	D11	43	14	PIN, LOCK, 10MM	C2	18	15	SCREW, PAN, 3X6.....	C14	30	22
LEVER, COCK	C14	30	18	PIN, PISTON	C8	24	3		C16	32	23
	C16	32	18	PIPE, EX.	D3	35	6	SCREW, PAN, 4X14.....	D10	42	27
LIFTER, VALVE	C9	25	5		D13	45	1	SCREW, PAN, 5X20.....	D9	41	23
				PISTON	C7	23	2	SCREW, PAN, 5X8.....	D6	38	16
					C8	24	2	SCREW, PAN, 6X6.....	D3	35	15
[M]				PIVOT, ROCKER ARM	C9	25	6	SCREW, RECESSED, 5X20.....	D9	41	23
MARK, OPERATOR CAUTION	D12	44	2	PLATE COMP., SUCTION	C3	19	14	SCREW, RECESSED, 5X35.....	D11	43	18

PART NAME INDEX

F 3

Part name	Address	Page	Ref.	Part name	Address	Page	Ref.	Part name	Address	Page	Ref.
SCREW, SPECIAL, 6X8	C13	29	8	VALVE, BREATHER	C2	18	5				
SCREW, TAPPING, 4X6	D3	35	12	VALVE, EX.	C9	25	9				
SCREW, TAPPING, 5X8	D3	35	11	VALVE, IN.	C9	25	8				
	D10	42	24	VALVE, ONE WAY	C2	18	8				
SCREW, THROTTLE STOP	C14	30	9								
	C16	32	9	[W]							
SEAL, VALVE STEM	C9	25	1	WASHER COMP., HEAD COVER	C1	17	13				
SEAT, VALVE SPRING	C9	25	13	WASHER, DRAIN PLUG, 10.2MM	C5	21	52				
SEPARATOR, MUFFLER	D3	35	2	WASHER, DRAIN PLUG, 20MM	C4	20	42				
SHAFT, GOVERNOR ARM	C2	18	9		C5	21	55				
SHROUD	C13	29	6	WASHER, OIL DRAIN, 24MM	C5	21	53				
SLIDER, GOVERNOR	C4	20	23	WASHER, PLAIN, 6MM	C4	20	40				
SPACER COMP., CARBURETOR	C14	30	15				41				
	C16	32	15				17				
SPACER, AIR CLEANER ELBOW	D2	34	10		D3	35	17				
SPONGE, FUEL CAP BREATHER	D4	36	9		D10	42	29				
SPRING, CABLE RETURN	D9	41	11		D11	43	22				
	D11	43	12	WASHER, PLAIN, 8MM	D4	36	12				
SPRING, COCK LEVER	C14	30	20	WASHER, SPRING, 4MM	D10	42	30				
	C16	32	20	WASHER, SPRING, 5MM	D10	42	31				
SPRING, CONTROL ADJUSTING	D9	41	10	WASHER, TANK MOUNTING	D4	36	11				
	D11	43	11	WASHER, THRUST	D8	40	14				
SPRING, FRICTION	C12	28	5	WASHER, THRUST, 15MM	C6	22	4				
SPRING, GOVERNOR	D9	41	7	WASHER, THRUST, 8.1MM	C2	18	11				
	D11	43	7	WEIGHT A, BALANCER	C6	22	2				
SPRING, GOVERNOR PRIMARY	D9	41	8	WEIGHT B, BALANCER	C6	22	3				
	D11	43	8	WEIGHT, GOVERNOR	C3	19	20				
SPRING, LEVER	D11	43	9	WRENCH, BOX	D12	44	4				
SPRING, RATCHET	C12	28	7								
SPRING, STARTER RETURN	C12	28	6	[Y]							
SPRING, VALVE	C9	25	10	YOKE COMP.	D8	40	3				
SPRING, WEIGHT RETURN	C9	25	7								
STARTER ASSY., RECOIL	C12	28	1								
STAY COMP., MUFFLER	D3	35	3								
STAY COMP., UNDER COVER	C1	17	9								
STAY, BUZZER	D9	41	18								
STOPPER SET, PINION	D8	40	5								
STOPPER, OIL	C3	19	10								
STRAINER COMP., FUEL	D4	36	1								
STRAINER, FUEL	D4	36	2								
SUSPENSION, AUDIBLE PILOT	D9	41	19								
SWITCH ASSY., ENGINE	D9	41	14								
SWITCH ASSY., ENGINE STOP	D9	41	16								
SWITCH ASSY., STARTER MAGNETIC	D8	40	13								
SWITCH COMP., OIL LEVEL	C4	20	25								
[T]											
TANK, FUEL	D4	36	3								
TUBE, AIR VENT	C14	30	13								
TUBE, BREATHER	C2	18	3								
TUBE, FUEL	D4	36	4								
TUBE, FUEL, 4.5X180	D1	33	24								
	D4	36	13								
[V]											
VALVE SET, FLOAT	C14	30	2								
	C16	32	2								

1

FOREWORD INDEX

2

ENGINE GROUP

3

PART NUMBER INDEX

4

PART NAME INDEX

HONDA
The Power of Dreams



PARTS CATALOGUE NEWS

Honda Motor Co., Ltd. Service Division

PARTS CATALOGUE - CORRECTED

Printed in Japan

CODE NO.	13Z5N602
PARTS CATALOGUE NEWS	GXV340UT2 GXV340RT2
NEWS NO.	001

Block No.	Ref. No.	Note	Part No.	Description	Reqd. QTY		Serial No.	Parts catalogue code
					GXV 340 UT2	GXV 340 RT2		
E-16	7	L	18333-ZE3-800	GASKET, EX. PIPE	1	-	----- 1018581	DA, DAS, DA2, DA23, DA33, DCAG, DET3, DE33, DNE4, DNG4, DN4, DXE2 DX2, DX3
		T	18333-Z1C-801	1	-	1018582 -----	DA, DAS, DA2, DA23, DA33, DCAG, DET3, DE33, DNE4, DNG4, DN4, DXE2 DX2, DX3
					-	1	----- -----	DA, DAS, DA2, DA23, DA33, DCAG
	9	L	18382-ZE9-800	GASKET, EX. PIPE	1	-	----- 1018581	DA, DAS, DA2, DA23, DA33, DCAG, DET3, DE33, DNE4, DNG4, DN4, DXE2 DX2, DX3
T		18382-Z1F-801	1	-	1018582 -----	DA, DAS, DA2, DA23, DA33, DCAG, DET3, DE33, DNE4, DNG4, DN4, DXE2 DX2, DX3	
					-	1	----- -----	DA, DAS, DA2, DA23, DA33, DCAG

NOTE A:PART NO. CHANGE D:NEWLY PROVIDED E:PART NO. DELETION K:REQUIRED NO. CORRECTION L:APPLICATION SERIAL NO. CORRECTION
T:APPLICATION CORRECTION Z:REMARKS CHANGE

PARTS CATALOGUE NEWS

BOOKNo. : 13Z5N602

Block No.	Ref. No.	Note	Part No.	Description	Reqd. QTY		Serial No.	Parts catalogue code
					GXV 340 UT2	GXV 340 RT2		

E-17 FUEL TANK

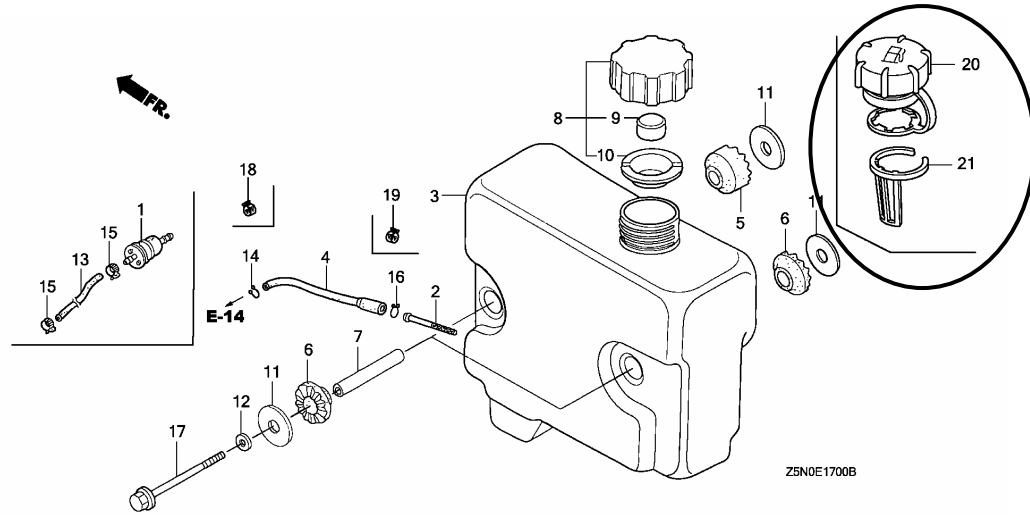

E-17	3	L	17510-ZE9-000	TANK, FUEL	1	-	-----	1018531	DET3, DE33, DNE4, DNG4, DN4, DXE2, DX2, DX3
		L	17511-Z5N-000		1	-	1018532	-----	DET3, DE33, DNE4, DNG4, DN4, DXE2, DX2, DX3
	4		17512-Z5N-003	TUBE, FUEL (FKM)	1	-	1004990	1018531	DET3, DE33, DNE4, DNG4, DN4, DXE2, DX2, DX3
		A	17512-Z5N-013		1	-	1018532	-----	DET3, DE33, DNE4, DNG4, DN4, DXE2, DX2, DX3
	8	L	17620-ZE7-000	CAP ASSY., FUEL TANK	1	-	-----	1020361	DET3, DE33, DNE4, DNG4, DN4, DXE2, DX2, DX3
	9	L	17622-888-010	SPONGE, FUEL CAP BREATHER	1	-	-----	1020361	DET3, DE33, DNE4, DNG4, DN4, DXE2, DX2, DX3
	10	L	17624-ZE7-000	PACKING, FUEL CAP	1	-	-----	1020361	DET3, DE33, DNE4, DNG4, DN4, DXE2, DX2, DX3
	13	L	95001-45230-50	HOSE, FUEL, 4.5X230 (95001-45001-50M)	1	-	-----	1026054	DAS
			91424-Z4K-801	TUBE, FUEL, 4.5X180 (FKM)	1	-	1013446	1026840	DCAG
					-	1	-----	1026840	DCAG
			91434-Z5P-801	HOSE, FUEL, 4.5X230 (FKM)	-	1	-----	1026054	DAS

NOTE A:PART NO. CHANGE D:NEWLY PROVIDED E:PART NO.DELETION K:REQUIRED NO. CORRECTION L:APPLICATION SERIAL NO. CORRECTION
T:APPLICATION CORRECTION Z:REMARKS CHANGE

PARTS CATALOGUE NEWS

BOOKNo. : 13Z5N602

Block No.	Ref. No.	Note	Part No.	Description	Reqd. QTY		Serial No.	Parts catalogue code
					GXV 340 UT2	GXV 340 RT2		
		A	91424-Z4K-802	TUBE, FUEL, 4.5X180 (FKM)	1	1	1026841 -----	DCAG
		A	91434-Z5P-802	HOSE, FUEL, 4.5X230 (FKM)	1	1	1026055 -----	DAS
	20	D	17620-Z0J-800	CAP ASSY., FUEL TANK	1	-	1020362 -----	DET3, DE33, DNE4, DNG4, DN4, DXE2, DX2, DX3
	21	D	17636-Z5N-000	GAUGE, FUEL LEVEL	1	-	1020362 -----	DET3, DE33, DNE4, DNG4, DN4, DXE2, DX2, DX3

NOTE A:PART NO. CHANGE D:NEWLY PROVIDED E:PART NO. DELETION K:REQUIRED NO. CORRECTION L:APPLICATION SERIAL NO. CORRECTION
T:APPLICATION CORRECTION Z:REMARKS CHANGE



PARTS CATALOGUE NEWS

Honda Motor Co., Ltd. Service Division

PARTS CATALOGUE - CORRECTED

Printed in Japan

CODE NO.	13Z5N602
PARTS CATALOGUE NEWS	GXV340UT2 GXV340RT2
NEWS NO.	002

Block No.	Ref. No.	Note	Part No.	Description	Reqd. QTY		Serial No.	Parts catalogue code
					GXV 340 UT2	GXV 340 RT2		
E-19	10	E	31630-ZE2-841	*PARTS NO. DELETION				
		T	31630-ZE2-842	COIL ASSY., CHARGE (3A)	1	1	-----	DM33

NOTE A:PART NO. CHANGE D:NEWLY PROVIDED E:PART NO.DELETION K:REQUIRED NO. CORRECTION L:APPLICATION SERIAL NO. CORRECTION
T:APPLICATION CORRECTION Z:REMARKS CHANGE